

GENERAL DESCRIPTION

The SGM42630 is a bipolar stepper motor driver suitable for automated positioning and movement control in equipment such as printers, scanners and robotic mechanisms. To control the stepper motor, two H-bridges are integrated in the device for the two motor windings along with a microstepping indexer logic. Bridge currents are regulated by chopping the motor supply voltage across the windings.

The step (STEP) and direction (DIR) inputs are provided for simple interfacing to the controller. The device also provides two microstepping input pins (USM0 and USM1) to choose the step size (full, half, quarter and eighth step).

Fast, slow and mixed (fast then slow) decay modes are selectable by applying proper voltage to DECAY input. Programmable blanking and off-time of the H-bridge PWM and selectable decay modes make the device very flexible and capable for driving a wide range of stepper motors with up to 2.6A per winding.

A number of protection features are provided in the device including under-voltage lockout, short-circuit, over-current and over-temperature shutdown.

The device is available in a Green TSSOP-28 (Exposed Pad) package.

FEATURES

- 8V to 35V Motor Power Supply Voltage Range
- PWM with up to 2.6A Current for each Winding
- Low On-Resistance: 0.29Ω for HS + LS, @ +25°C
- Microstepping Indexer: 1, 1/2, 1/4 and 1/8
- Step and Direction Interface
- Programmable Decay, Blanking and Off-Time
- Auto-Decay Mode
- UVLO for VM, VCC, VCP, VGD Voltages
- Over-Current Protection (OCP)
- Thermal Shutdown (TSD)
- Available in a Green TSSOP-28 (Exposed Pad) Package

APPLICATIONS

- Robotic Mechanisms
- Textile Equipment
- Scanners
- Positioning and Tracking
- Printers

SIMPLIFIED SCHEMATIC

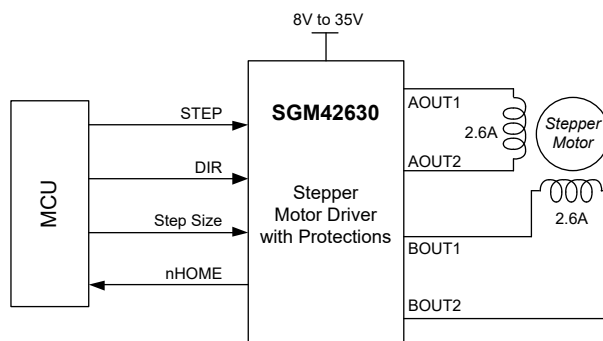

PACKAGE/ORDERING INFORMATION

MODEL	PACKAGE DESCRIPTION	ORDERING NUMBER	PACKAGE MARKING	PACKING OPTION
SGM42630	TSSOP-28 (Exposed Pad)	SGM42630YPTS28G/TR	SGM42630 YPTS28 XXXXX	Tape and Reel, 4000

MARKING INFORMATION

NOTE: XXXXX = Date Code, Trace Code and Vendor Code.

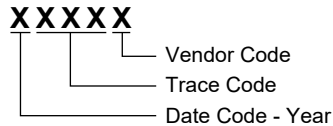

Green (RoHS & HSF): SG Micro Corp defines "Green" to mean Pb-Free (RoHS compatible) and free of halogen substances. If you have additional comments or questions, please contact your SGMICRO representative directly.

ABSOLUTE MAXIMUM RATINGS

- Motor Power Supply Voltage Range, V_M (V_{MA} or V_{MB})..... -0.3V to 38V
- Logic Power Supply Voltage Range, V_{CC} -0.3V to 6V
- Digital Pins Input Voltage Range -0.5V to 6V
- VREF Input Voltage, V_{REF} 0V to V_{CC}
- ISENx Pins Voltage..... -0.5V to 0.875V
- Peak Output Current (Motor Drive) Limited Internally
- Package Thermal Resistance
TSSOP-28 (Exposed Pad), θ_{JA} 32°C/W
- Operating Junction Temperature..... +150°C
- Storage Temperature Range..... -65°C to +150°C
- Lead Temperature (Soldering, 10s) +260°C
- ESD Susceptibility
HBM..... 4000V
CDM 1000V

ESD SENSITIVITY CAUTION

This integrated circuit can be damaged if ESD protections are not considered carefully. SGMICRO recommends that all integrated circuits be handled with appropriate precautions. Failure to observe proper handling and installation procedures can cause damage. ESD damage can range from subtle performance degradation to complete device failure. Precision integrated circuits may be more susceptible to damage because even small parametric changes could cause the device not to meet the published specifications.

DISCLAIMER

SG Micro Corp reserves the right to make any change in circuit design, or specifications without prior notice.

RECOMMENDED OPERATING CONDITIONS

- Motor Power Supply Voltage Range ⁽¹⁾, V_M8V to 35V
- Logic Power Supply Voltage Range, V_{CC}3V to 5.5V
- VREF Input Voltage, V_{REF}0 to V_{CC}
- R_X Resistance Value, R_X 12kΩ to 100kΩ
- C_X Capacitance Value, C_X 470pF to 3000pF
- Operating Junction Temperature Range..... -40°C to +150°C

NOTE: 1. VMA and VMB pins must be tied to the same source (VM).

OVERSTRESS CAUTION

Stresses beyond those listed in Absolute Maximum Ratings may cause permanent damage to the device. Exposure to absolute maximum rating conditions for extended periods may affect reliability. Functional operation of the device at any conditions beyond those indicated in the Recommended Operating Conditions section is not implied.

PIN CONFIGURATION

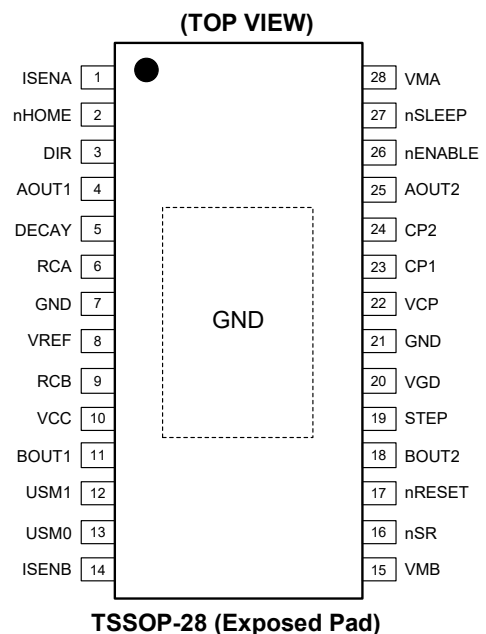

PIN DESCRIPTIONS

PIN		TYPE	FUNCTION
NO.	NAME		
1	IENA	-	Bridge A I _{SENSE} (GND). Connect with a sensing resistor to power ground.
2	nHOME	O	Home Position Logic Output. Pull this pin low when step table is at home state and high at other states.
3	DIR	I	Direction Input Pin. Control the direction of stepping. It has a weak internal pull-down.
4	AOUT1	O	Bridge A Node 1. Connect to one end (+) of the stepper motor winding A.
5	DECAY	I	Decay Mode Select with Weak Internal Pull-Down. Voltage applied to this pin sets one of the three decay modes. See details in motor driver description. A 0.1μF ~ 0.22μF capacitor needs to be placed between DECAY and GND pins.
6	RCA	I	Bridge A Blanking and Off-Time Setting. Connect to the parallel programming resistor (R _A) and capacitor (C _A). See Current Regulation section for the adjustment details and Equations 2, 3 and 4.
7, 21	GND	-	Ground Reference.
8	VREF	I	Reference Voltage for Current Set. Apply the reference voltage to set the full-scale winding current value.
9	RCB	I	Bridge B Blanking and Off-Time Setting. Connect to the parallel programming resistor (R _B) and capacitor (C _B). See Current Regulation section for the adjustment details and Equations 2, 3 and 4.
10	VCC	-	Digital Logic Supply Voltage (3V to 5.5V). A 0.1μF ceramic decoupling capacitor needs to be placed between VCC and GND pins.
11	BOUT1	O	Bridge B Node 1. Connect to one end (+) of the stepper motor winding B.
12	USM1	I	Micro-Step Mode Selection Logic Input 1. USM0 and USM1 are logic inputs to set the step size to one of the 4 options (full, half, quarter and eight micro-steps/step). It has a weak internal pull-down.
13	USM0	I	Micro-Step Mode Selection Logic Input 0. USM0 and USM1 are logic inputs to set the step size to one of the 4 options (full, half, quarter and eight micro-steps/step). It has a weak internal pull-down.
14	IENB	-	Bridge B I _{SENSE} (GND). Connect to VM power ground through the current sense resistor for bridge B.
15	VMB	-	Power Supply for Bridge B. Connect to the motor power supply (8V to 35V). VMA and VMB pins should be tied to the same supply.
16	nSR	I	Synchronous Rectification Enable Input. Synchronous rectification is enabled if nSR pin is pulled low. Float nSR pin to enter the auto-decay mode with synchronous rectification. With nSR = high there is no synchronous rectification and body diodes conduct the reverse current. In this case maximum body diode currents must be guaranteed to be less than 1.3A.
17	nRESET	I	Reset Input. Active low reset with weak internal VCC pull up to initializes microstepping indexer logic and disable H-bridge outputs.
18	BOUT2	O	Bridge B Node 2. Connect to the other end (-) of the stepper motor winding B. I _B is positive from BOUT1 to BOUT2.
19	STEP	I	Step Logic Input. Rising edge causes the microstepping indexer to move one step. It has a weak internal pull-down.
20	VGD	IO	Gate Drive Voltage of the Low-side Switches. Decouple to GND with a 0.22μF ceramic capacitor.
22	VCP	IO	Gate Drive Voltage of the High-side Switches. Decouple with a 0.22μF ceramic capacitor to VM pin.
23	CP1	IO	Charge Pump Flying Capacitor. A 0.22μF capacitor is used between CP1 and CP2 pins.
24	CP2	IO	
25	AOUT2	O	Bridge A Node 2. Connect to the other end (-) of the stepper motor winding A. I _A is positive from AOUT1 to AOUT2.
26	nENABLE	I	Enable Input. Active low enable logic input with weak internal pull-up to VCC. A low enables outputs.
27	nSLEEP	I	Sleep Mode Input. Active low sleep mode logic input with weak internal pull-down. Apply high to enable device, and low to enter in the low-power sleep mode.
28	VMA	-	Power Supply for Bridge A. Connect to the motor power supply (8V to 35V). VMA and VMB pins should be tied to the same supply.
Exposed Pad	GND	G	Ground.

NOTE: Directions: I = input, O = output, IO = input or output, G = ground.

ELECTRICAL CHARACTERISTICS

(T_J = +25°C, Full = -40°C to +85°C, unless otherwise noted.)

PARAMETER	SYMBOL	CONDITIONS	TEMP	MIN	TYP	MAX	UNITS
Power Supply							
Motor Power Supply Voltage	V _M		+25°C	8	12 or 24	35	V
Logic Power Supply Voltage	V _{CC}		+25°C	3	3.3	5.5	V
VM Operating Supply Current	I _{VM}	V _M = 35V, f _{PWM} < 50kHz	+25°C		0.45	0.6	mA
VCC Operating Supply Current	I _{VCC}	f _{PWM} < 50kHz	+25°C		1.1	1.5	mA
VM Sleep Mode Supply Current	I _{VMQ}	V _M = 35V	+25°C		20	330	nA
VCC Sleep Mode Supply Current	I _{VCCQ}		+25°C		12	15	μA
VM Under-Voltage Lockout Voltage	V _{M_UVLO}	V _M rising	+25°C		6.7	7	V
VCC Under-Voltage Lockout Voltage	V _{CC_UVLO}	V _{CC} rising	+25°C		2.72	2.95	V
VREF Input							
VREF Input Current	I _{REF}	V _{REF} = 3.3V	+25°C	-3		3	μA
Chopping Current Accuracy	ΔI _{CHOP}	V _{REF} = 2.0V, 70% current	+25°C	-10		10	%
Logic Inputs							
Pull-Up Resistance	R _{PU}	nENABLE, nRESET	+25°C		270		kΩ
Pull-Down Resistance	R _{PD}	DIR, STEP, nSLEEP, USM1, USM0, nSR	+25°C		270		kΩ
Input Low Voltage	V _{IL}		Full			0.2 × V _{CC}	V
Input High Voltage	V _{IH}		Full	0.8 × V _{CC}			V
Input Hysteresis	V _{HYS}		+25°C		0.4 × V _{CC}		V
nHOME Output							
Output Low Voltage	V _{OL}	I _O = 200μA	+25°C			0.3 × V _{CC}	V
Output High Voltage	V _{OH}	I _O = -200μA	+25°C	0.7 × V _{CC}			V
DECAY Input							
Low Threshold	V _{IL}	To select fast decay mode	+25°C		0.2 × V _{CC}		V
Mid Level Threshold	V _{MID}	To select mixed decay mode	+25°C		0.2 × V _{CC} to 0.6 × V _{CC}		V
High Threshold	V _{IH}	To select slow decay mode	+25°C		0.6 × V _{CC}		V
H-Bridge FETs							
LS + HS FET On-Resistance	R _{DS(ON)}	V _M = 24V, I _O = 0.4A	+25°C		290	380	mΩ
Off-State Leakage Current	I _{OFF}		+25°C	-15		15	μA
Protection							
Thermal Shutdown Temperature	T _{TSD}		+25°C		160		°C
Over-Current Protection	I _{OC}		+25°C		3.2		A
OCP Deglitch Time	t _{OC}		+25°C		1.5		μs
OCP Retry Time	t _{RET}		+25°C		1		s
Motor Driver							
Off-Time	t _{OFF}	R _X = 56kΩ, C _X = 680pF	+25°C	30	42	52	μs
Current Sense Blanking Time	t _{BLANK}	R _X = 56kΩ, C _X ≤ 1500pF	+25°C		2		μs
Dead Time	t _{DT}	nSR = 0	+25°C	100	200	800	ns
Rise Time	t _R		+25°C	15		80	ns
Fall Time	t _F		+25°C	15		80	ns

TIMING PARAMETERS AND REQUIREMENTS

(T_J = +25°C, unless otherwise noted.)

SYMBOL	FUNCTION	MIN	MAX	UNITS
f _{STEP}	Step frequency.		500	kHz
t _{WH (STEP)}	Step pulse high duration.	1		μs
t _{WL (STEP)}	Step pulse low duration.	1		μs
t _{SU (STEP)}	Command set-up time, before STEP rising.	250		ns
t _{H (STEP)}	Command hold time, after STEP rising.	250		ns
t _{WAKE}	Wake-up time, exit sleep (nSLEEP rising) to STEP input cannot be accepted.		1	ms
t _{nSLEEP}	Sleep time, enter sleep (nSLEEP falling) to outputs disabled.		2.5	μs
t _{nENABLE}	Enable time, enable (nENABLE falling) to outputs enabled.		20	μs
t _{DISABLE}	Disable time, disable (nENABLE rising) to outputs disabled.		20	μs
t _{nRESETR}	Reset release time, (nRESET rising) to outputs enabled.		5	μs
t _{nRESET}	Reset time, (nRESET falling) to outputs disabled.		5	μs

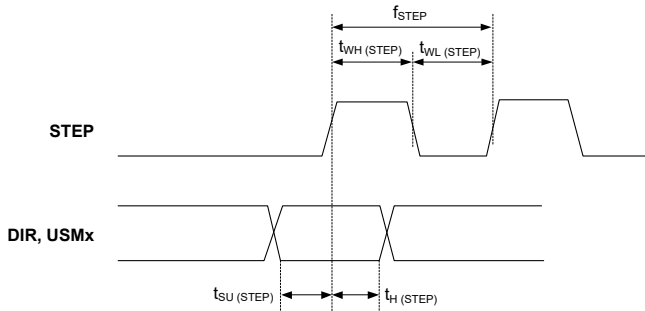

Figure 1. STEP Timing Definition

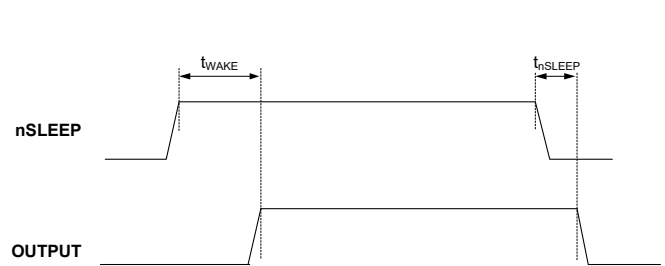

Figure 2. nSLEEP Timing Definition

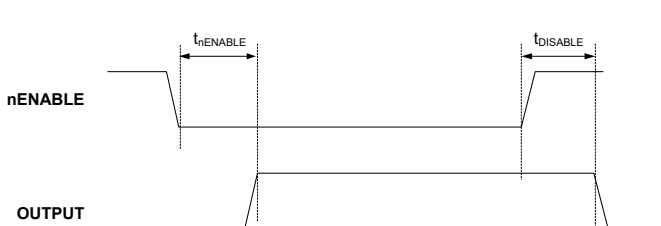

Figure 3. nENABLE Timing Definition

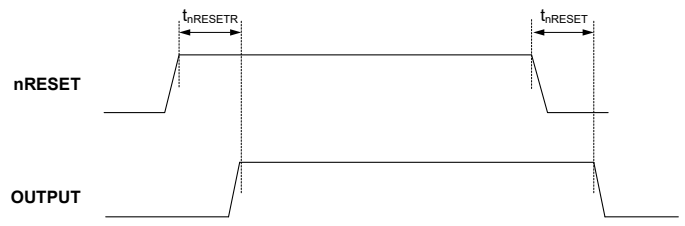
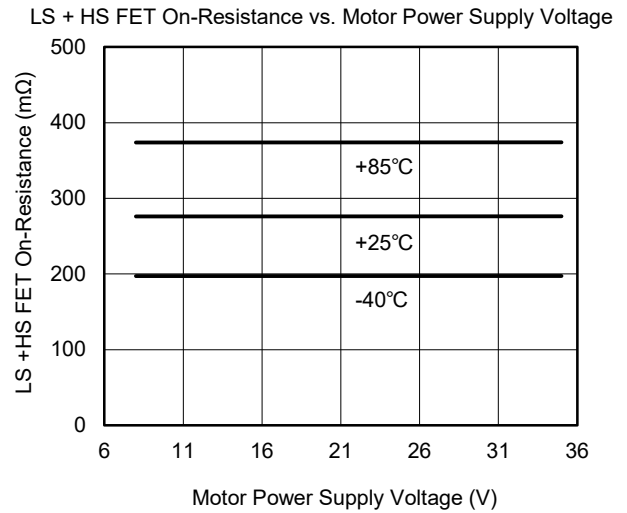
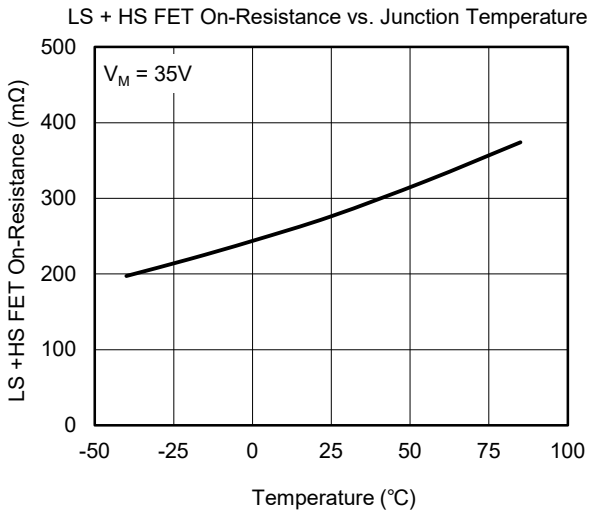
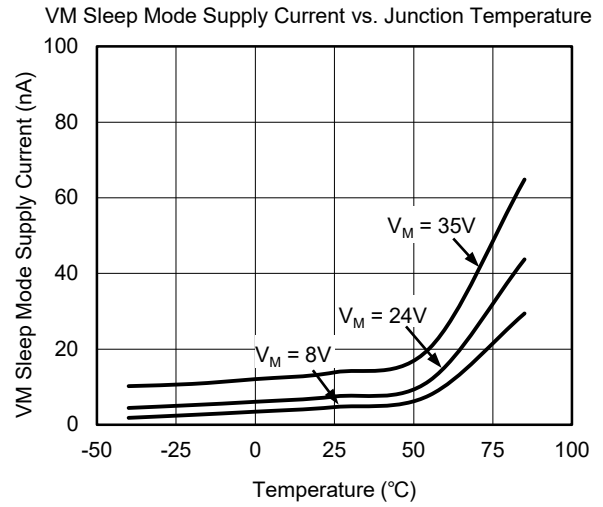
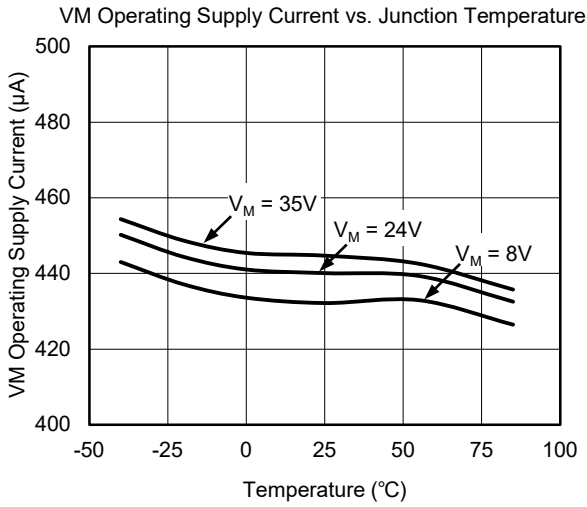
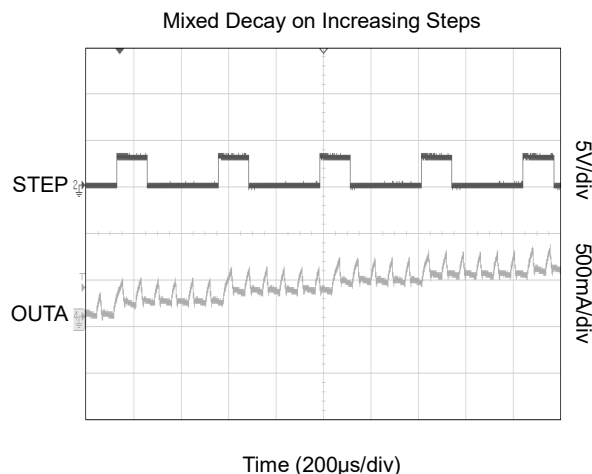
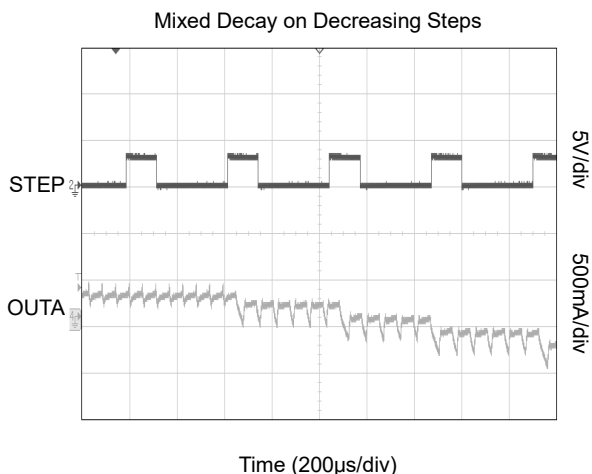
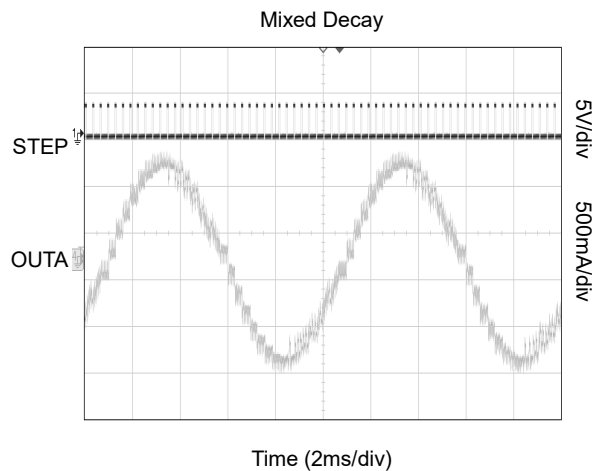
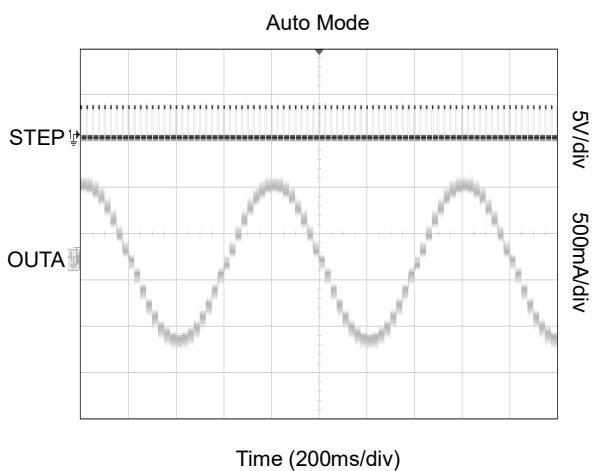

Figure 4. nRESET Timing Definition

TYPICAL PERFORMANCE CHARACTERISTICS



TYPICAL PERFORMANCE CHARACTERISTICS (continued)



FUNCTIONAL BLOCK DIAGRAM

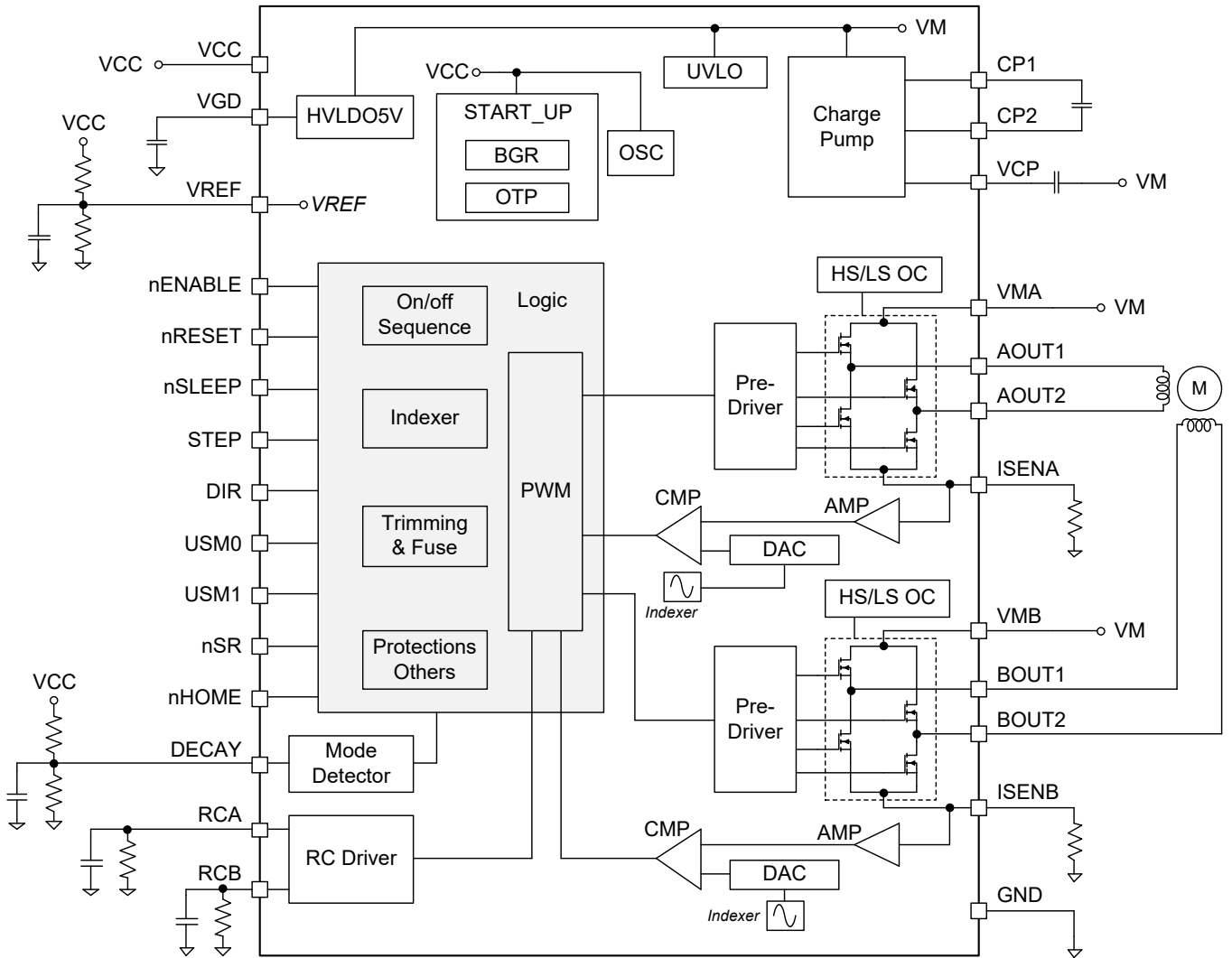

DETAILED DESCRIPTION

Overview

The SGM42630 is a flexible, bipolar stepper motor driver including two integrated H-bridges with current sense and regulation control plus a microstepping indexer. It accepts 8V to 35V motor power supply voltages and can deliver up to 2.6A for each winding. Sleep mode can be used to minimize power consumption by the driver when is idle. It is an easy to use driver thanks to its STEP and DIR inputs and the internal indexer. It is by itself capable for accurate microstepping without current loop regulation or controller management.

Decay mode is chosen based on the application needs. For the SGM42630 fast, slow and mixed decay mode options are available for flexible current regulation.

The driver can be adjusted to a wide range of stepper motors by setting proper values for mixed decay, blanking, and off-time.

Decay Mode

The current continues to flow in the same direction during the off-time due to the large inductance of the winding. There are two options for current flow direction in the bridge switches during the off-time. Suppose that by chopping, the drive current path S1 is stopped (by turning off M₁ or M₁ & M₄) in Figure 5. Then during the off-time the bridge can act in two different ways: the current can be decayed by letting it circulate through the lower switches (recirculation in M₂/D₂ and M₄, shown as path S0) or it can recycle the inductor energy back to the V_M source through M₂/D₂ and M₃/D₃ in path S2. In the former case, the voltage across the winding will be almost zero and current decay will be slow (slow decay) but in the latter case, the voltage across the winding is -V_M and current decays in a faster rate (fast decay), tending to reverse its direction. If synchronous mode is on, switches are turned on to conduct rather than their body diodes, otherwise the diodes will conduct the reverse current naturally. A short dead time is always implemented before turning on M₃ to avoid shoot through in M₃-M₄ leg (similarly for the M₁-M₂ leg). Synchronous rectification can be enabled by setting nSR pin to logic low to use MOSFET on-channels rather than their body diodes for conduction and reduce losses. In synchronous mode, current reversal is not allowed and bridge is disabled when the current approaches zero. (It is not recommended to disable synchronous rectification unless it is guaranteed that body diode currents remain below 1.3A.)

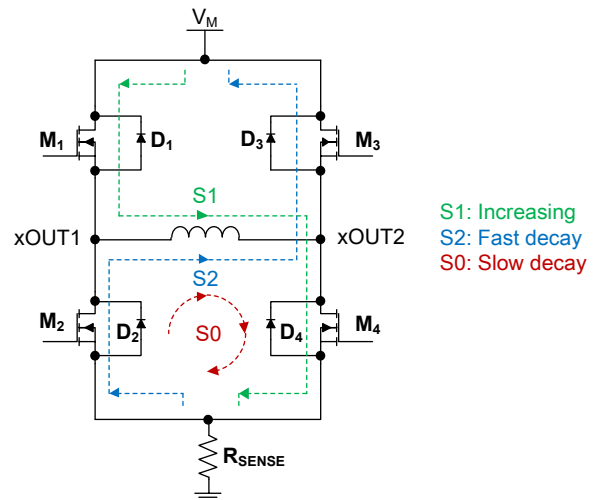

Figure 5. Slow and Fast Decay Modes Current Paths

Mixed decay mode is also supported in which decay starts in fast mode for a programmed period of time (t_{FD}) and then shifts to the slow decay mode for the remainder of the fixed off-time.

Decay mode (for decreasing current) is selected by the voltage on the DECAY pin (V_{DECAY}). If the voltage is higher than 0.6 × V_{CC}, slow decay mode is selected and if it is less than 0.2 × V_{CC}, fast decay mode is used. When V_{DECAY} is between these levels, mixed decay mode is enabled and the duration of fast portion (t_{FD}) is determined by V_{DECAY} as approximated by (1):

$$t_{FD} = R \times C \times \ln\left(\frac{0.6 \times V_{CC}}{V_{DECAY}}\right) \quad (1)$$

where R and C are the same resistor and capacitor connected to RCx inputs.

Figure 6 shows the blanking, fixed off-time and the mixed decay mode for two PWM cycles. Each step (or micro-step) may last for several PWM cycles depending on the speed of rotation and the DC current level is maintained by PWM chopping during the step time. Current ripple is smaller with shorter PWM off-time and higher V_M voltage.

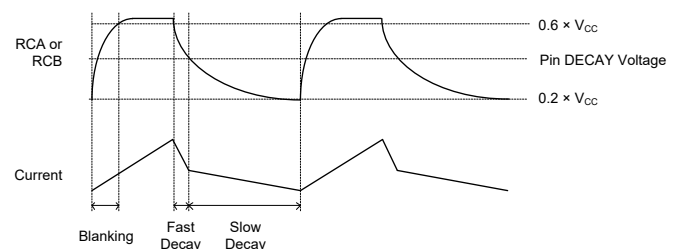
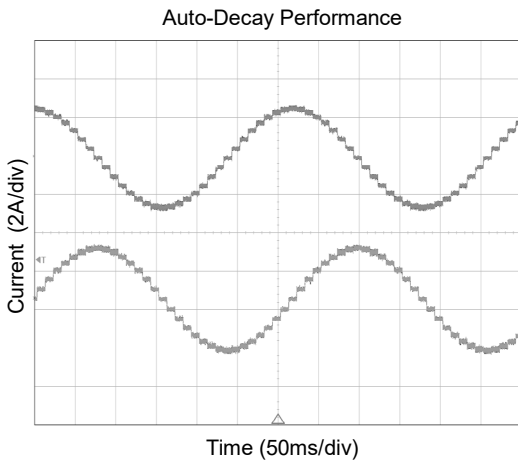

Figure 6. PWM Waveform

DETAILED DESCRIPTION (continued)

Auto-Decay Mode

The device features an auto-decay mode in which it can shift between mixed decay and slow decay automatically to minimize current ripple. No external decay setting is needed in this mode. The chip enters auto-decay mode when nSR pin is floating.



Current Regulation

PWM chopping is used for current regulation in the H-bridges. Motor windings typically have a large inductance of a few mH with a few ohms of DC resistance. H-bridge can apply V_M , 0 or $-V_M$ voltage across the winding and the current will start to rise or fall depending on the applied voltage and polarity with a time constant (L/R). Bridge current is sensed across shunt resistor connected to ISENx and is multiplied by a gain of 8 before being compared to the current setting reference voltage coming from VREF input and scaling DACs. Each PWM pulse will turn off (chopped) when the comparator detects that the trip current level is reached. The maximum current deliverable to the winding (100% or full-scale) can be calculated by (2):

$$I_{FS} = \frac{V_{REF}}{8 \times R_{SENSE}} \tag{2}$$

Assuming $R_{SENSE} = 0.1\Omega$ and $V_{REF} = 1.8V$, the chopping current (100%full-scale) will be 2.25A.

Microstepping is commonly used to get fractional step sizes and smoother rotation. With microstepping the windings currents (I_A and I_B) are scaled with predetermined ratios stored in a table, such that the resulting magnetic field vector direction inside the motor can be adjusted with small angle steps while keeping the magnitude relatively constant for a steady torque. Microstepping allows for very fine steps and much less mechanical and electrical noise generation. The cost is lower rotation speed and less than maximum torque. Scaling of the current is implemented by weighting the reference voltage using the DACs. The microstepping indexer table is preloaded with the scale values of each micro-step. More details are given in the Microstepping Indexer section.

When the H-bridge starts a PWM pulse, the transient noise may affect the current sensing circuit and cause false detection. Therefore, for a short current sense blanking time (t_{BLANK}) that is typically a few microseconds the current sensing is ignored. After the blanking time, the current is sensed and when the reference (chopping current value) is reached, the pulse is switched off for a fixed off-time (t_{OFF}) duration. The resistor and capacitor connected to the RCx pins, determine the blanking and off-time of bridge x (A or B) that are approximated by (3) and (4):

$$t_{OFF} = R \times C \tag{3}$$

$$t_{BLANK} = 1400 \times C \tag{4}$$

The recommended selection range for Rx is 12kΩ to 100kΩ and for Cx is 0.47nF to 3nF. t_{BLANK} has a typical value of 2μs.

DETAILED DESCRIPTION (continued)

Microstepping Indexer

Table 1 shows four main microstepping configurations that are selectable for the embedded indexer using USM1 and USM0 pins. The scaling values of A and B currents for microstepping and the resulting step sizes for all 4 options of USM1/USM0 (00, 01, 10, 11) are shown in Table 2 for DIR = high direction.

With each rising edge of the STEP input, the indexer goes to the next state in the table. With DIR = low the sequence is reversed. Current is defined positive when it flows from OUT1 to OUT2. This specific values form a near sinusoidal current in the windings (I_A and I_B) when motor is stepped in a constant speed, resulting in very small audible noise and vibration (wave microstepping).

The scale values set the chopping threshold (I_{TRIP}) for current regulation as a percentage of the full-scale current (I_{FS}) for each step. The home state is at 45° in which A and B windings are both excited with equal 71% of I_{FS} . After a reset or power up, the indexer will reset to the home state and output nHOME pin is driven low only at this state.

Table 1. Microstepping Selection Bits

USM1	USM0	Step Mode
0	0	Full step (2-phase excitation)
0	1	1/2 step (1-2 phase excitation)
1	0	1/4 step (W1-2 phase excitation)
1	1	1/8 step

Table 2. Microstepping Indexer with DIR = 1 Direction

Full Step Pulsing (USM = 00)	1/2 Step Pulsing (USM = 01)	1/4 Step Pulsing (USM = 10)	1/8 Step Pulsing (USM = 11)	AOUTx Current (% Full-Scale)	BOUTx Current (% Full-Scale)	Step Angle (°)
	1	1	1	100	0	0
			2	98	20	11.25
		2	3	92	38	22.5
			4	83	56	33.75
1	2	3	5	71	71	45 (home state)
			6	56	83	56.25
		4	7	38	92	67.5
			8	20	98	78.75
	3	5	9	0	100	90
			10	-20	98	101.25
		6	11	-38	92	112.5
			12	-56	83	123.75
2	4	7	13	-71	71	135
			14	-83	56	146.25
		8	15	-92	38	157.5
			16	-98	20	168.75
	5	9	17	-100	0	180
			18	-98	-20	191.25
		10	19	-92	-38	202.5
			20	-83	-56	213.75
3	6	11	21	-71	-71	225
			22	-56	-83	236.25
		12	23	-38	-92	247.5
			24	-20	-98	258.75
	7	13	25	0	-100	270
			26	20	-98	281.25
		14	27	38	-92	292.5
			28	56	-83	303.75
4	8	15	29	71	-71	315
			30	83	-56	326.25
		16	31	92	-38	337.5
			32	98	-20	348.75

DETAILED DESCRIPTION (continued)

Protection Circuits

Over-Current Protection (OCP)

Each MOSFET is protected by its own preset over-current limit. In case of an over-current (any direction), the whole bridge will be disabled (shutdown) for about 1s, or until nENABLE pin is toggled high and low, or until power is recycled. An over-current may occur due to a short between a switching node and ground or to the V_M supply line or to the other node of the bridge (a winding short). Current protections are independent of PWM current sensing or V_{REF} voltage. (If synchronous rectification is disabled, current should not exceed 1.3A in body diodes.)

Microstepping indexer will be reset to the home state if an over-current shutdown happens.

Thermal Shutdown (TSD)

All bridges and drivers are shutdown if a junction over temperature occurs in the device and the microstepping indexer is reset to the home state. Once the temperature goes back to the safe level, device resumes its operation.

Under-Voltage Lockout (UVLO)

If any of the source voltage (V_{MA} , V_{MB} , V_{CP} , V_{GD} or V_{CC}) falls below the under-voltage lockout threshold, device will be disabled, and the microstepping indexer resets to the home state. Device resumes operation when all of them go back above their UVLO thresholds.

nRESET

When the nRESET pin is pulled low, the H-bridges are both disabled and the microstepping indexer is reset to the home state. Pulses on the STEP input are ignored while nRESET is low.

nENABLE

The nENABLE pin controls the H-bridge drivers but has no effect on the control logic or microstepping indexer operation. Output drivers are enabled when nENABLE is low, and will go to the high impedance state when nENABLE is high. Other controls including the indexer STEP and DIR inputs are functional when nENABLE is high.

nSLEEP

To idle the device and put it in the low-power sleep mode, the nSLEEP pin can be pulled low. In the sleep mode, all H-bridges are disabled, internal clocks are paused and the charge pumps for the gate drivers are stopped. All logic inputs are ignored in sleep mode.

APPLICATION INFORMATION

Figure 7 shows a typical system application circuit of the SGM42630 for driving a bipolar stepper motor with the design requirements given in Table 3.

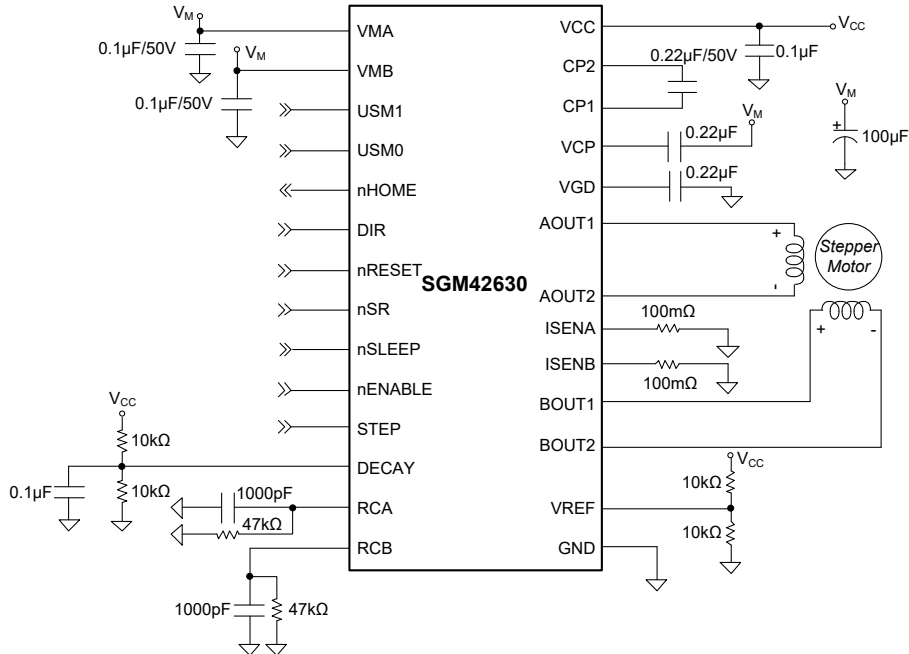

Figure 7. Typical Application Schematic

Table 3. Design Parameters

Design Parameter	Example Value
Power Supply Voltage, V _M	24V
Motor Winding Resistance, R _L	4.0Ω
Motor Winding Inductance, I _L	3.7mH
Motor Full Step Angle, θ _{step}	1.8°/step
Target Microstepping Level, n _m	8 micro-steps/step
Target Motor Speed, v	120rpm
Target Full-Scale Current, I _{FS}	1.25A

Detailed Design Procedure

Rotation speed (rpm) and micro-step/step number (n_m) determine the pulse frequency needed for the SGM42630 driver. If a constant speed is required, a pulse sequence with frequency of f_{STEP} should be applied to the STEP pin. A high micro-step/step number, results in smoother motion and low vibration and audible noise. The drawbacks of the high n_m number are higher switching losses due to higher f_{STEP} needed and less torque in the motor plus the risk of motor stall if torque/speed requirements are not considered. Motors

have different mechanical speed limits for startup and running that are controlled by step frequency. Moreover, there are maximum torque limits (for acceleration or deceleration) that are mainly controlled by current. So, proper acceleration and stepping profiles must be considered in the controller to match the application needs. Using the SGM42630 as driver, the controller can set the n_m using USM0 and USM1 inputs.

Equation 5 gives the required step frequency (f_{STEP}) to run a motor with the rotational speed v (rpm), when n_m micro-step/step is used for a motor with a full step angle of θ_{step} degrees per step (°/step):

$$f_{STEP} \text{ (Hz)} = \frac{\mu\text{steps}}{\text{sec}} = \frac{v \text{ (rpm)} \times 360 \text{ (°/Rotation)} \times n_m \left(\frac{\mu\text{steps}}{\text{step}} \right)}{60 \text{ (sec/min)} \times \theta_{step} \text{ (°/step)}} \quad (5)$$

For this application the required step frequency for speed of 120rpm (2 turns/sec) will be:

$$f_{STEP} = \frac{120 \times 360 \times 8}{60 \times 1.8} = 3200\text{Hz} \quad (6)$$

APPLICATION INFORMATION (continued)

Current Regulation Setting

The full-scale current (I_{FS}) is the maximum current that can be driven through each winding. As explained in the current regulation section, with V_{REF} analog voltage input and R_{SENSE} sense resistor, the full scale current is given by Equation 7.

$$I_{FS} (A) = \frac{V_{REF} (V)}{A_V \times R_{SENSE} (\Omega)} = \frac{V_{REF} (V)}{8 \times R_{SENSE} (\Omega)} \quad (7)$$

where $A_V = 8$ is the internal current sense gain of the SGM42630 applied on the shunt resistor voltage before reaching the comparator. Winding inductance and the total driving path resistance (winding, H-bridge switches and R_{SENSE}) determine the time constant (L/R) of the winding that along with the motor supply voltage (V_M) determine the rise and fall times of the winding current during a PWM pulse. I_{FS} defines the maximum current chopping threshold (I_{TRIP}). Note that the chopping frequency is higher and independent of the step frequency that determines the mechanical speed of the rotor.

Bulk and Decoupling Capacitance on Motor Supply

To achieve small voltage ripple and decouple the impact of supply line inductances from interfering with the system operation some bulk local capacitance near the motor driver (V_M supply) is needed as shown in Figure 8. Also, to decouple switching currents of the H-bridges, small high frequency decoupling capacitor is recommended between VMx and GND pins.

To select the local capacitance, several factors should be considered including the following:

- ♦ Maximum current needed by the motor.
- ♦ Supply capacitance and current sourcing capability.
- ♦ Parasitic inductance of supply lines.
- ♦ Acceptable voltage ripple.
- ♦ Motor parameters and required acceleration.

The power supply inductance causes drops and oscillation on V_M line if the local bulk capacitance is insufficient.

Motor datasheets generally advise for the capacitance value, however it is recommended to do a system level test to size the bulk capacitors properly.

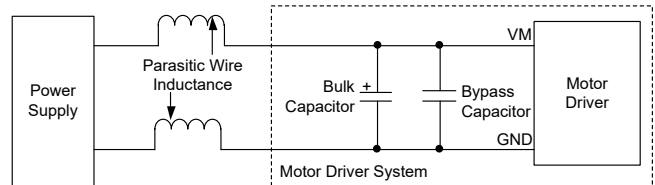

Figure 8. Example Set-Up of Motor Drive System with External Power Supply

Capacitor voltage rating should be considered well higher than the operating voltage, to provide enough margin when the energy transfer is reversed from motor windings back to the V_M supply line and they get charged by the driver.

REVISION HISTORY

NOTE: Page numbers for previous revisions may differ from page numbers in the current version.

JANUARY 2022 – REV.A.2 to REV.A.3		Page
<hr/>		
Updated Timing Parameters and Requirements section	5	5
<hr/>		
OCTOBER 2021 – REV.A.1 to REV.A.2		Page
<hr/>		
Updated Typical Performance Characteristics section	7	7
Updated Detailed Description section	11	11
Updated Package Outline Dimensions section	17	17
<hr/>		
JANUARY 2021 – REV.A to REV.A.1		Page
<hr/>		
Updated Absolute Maximum Ratings section.....	2	2
<hr/>		
Changes from Original (DECEMBER 2019) to REV.A		Page
<hr/>		
Changed from product preview to production data.....	All	All
<hr/>		

PACKAGE OUTLINE DIMENSIONS

TSSOP-28 (Exposed Pad)

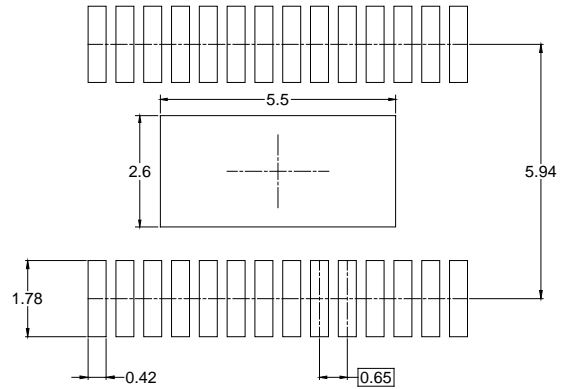
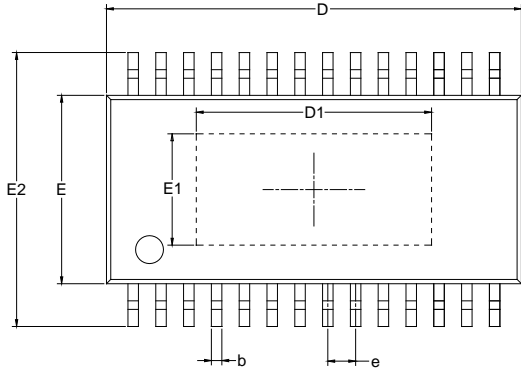

RECOMMENDED LAND PATTERN (Unit: mm)

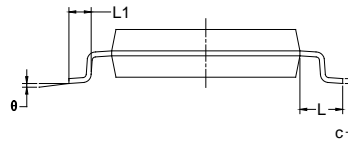
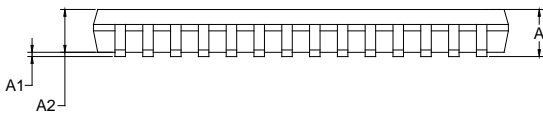

Symbol	Dimensions In Millimeters		Dimensions In Inches	
	MIN	MAX	MIN	MAX
A		1.200		0.047
A1	0.050	0.150	0.002	0.006
A2	0.800	1.050	0.031	0.041
b	0.190	0.300	0.007	0.012
c	0.090	0.200	0.004	0.008
D	9.600	9.800	0.378	0.386
D1	5.300	5.700	0.209	0.224
E	4.300	4.500	0.169	0.177
E1	2.400	2.800	0.094	0.110
E2	6.200	6.600	0.244	0.260
e	0.650 BSC		0.026 BSC	
L	1.000 BSC		0.039 BSC	
L1	0.450	0.750	0.018	0.030
θ	0°	8°	0°	8°

NOTES:

1. Body dimensions do not include mode flash or protrusion.
2. This drawing is subject to change without notice.

PACKAGE INFORMATION

TAPE AND REEL INFORMATION

REEL DIMENSIONS



TAPE DIMENSIONS



NOTE: The picture is only for reference. Please make the object as the standard.

KEY PARAMETER LIST OF TAPE AND REEL

Package Type	Reel Diameter	Reel Width W1 (mm)	A0 (mm)	B0 (mm)	K0 (mm)	P0 (mm)	P1 (mm)	P2 (mm)	W (mm)	Pin1 Quadrant
TSSOP-28 (Exposed Pad)	13"	17.6	6.80	10.20	1.60	4.0	8.0	2.0	16.0	Q1

000001

PACKAGE INFORMATION

CARTON BOX DIMENSIONS



NOTE: The picture is only for reference. Please make the object as the standard.

KEY PARAMETER LIST OF CARTON BOX

Reel Type	Length (mm)	Width (mm)	Height (mm)	Pizza/Carton
13"	386	280	370	5

DD0002