

60V (V_{DS}) / 25A (I_D) N-Channel Enhancement-Mode MOSFET

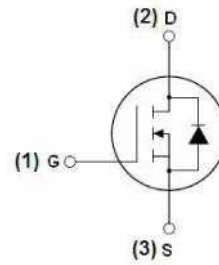

Schematic diagram

General Features

- $V_{DS}=60V$, $I_D=25A$ $R_{DS(ON)} < 32m\Omega$ @ $V_{GS}=10V$
- High density cell design for ultra low R_{dson}
- Fully characterized avalanche voltage and current
- Good stability and uniformity with high EAS
- Excellent package for good heat dissipation

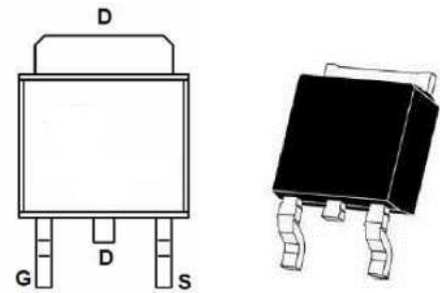

TO-252

Absolute Maximum Ratings ($T_A=25^\circ\text{C}$ unless otherwise noted)

Parameter	Symbol	Limit	Unit
Drain-Source Voltage	V_{DS}	60	V
Gate-Source Voltage	V_{GS}	± 20	V
Drain Current-Continuous	I_D	25	A
		$T_C = 100^\circ\text{C}$	
Drain Current –Pulsed ^a	I_{DM}	60	A
Power Dissipation	P_D	45	W
Derating factor		0.3	W/ $^\circ\text{C}$
Operating Junction and Storage Temperature Range	T_J, T_{STG}	-55 To 175	$^\circ\text{C}$
Single pulse avalanche energy (Note 5)	EAS	72	mJ
Thermal Resistance, Junction-to-Ambient ¹ (Note2)	$R_{\theta JA}$	3.3	$^\circ\text{C}/\text{W}$

Absolute Maximum Ratings (TA=25°C unless otherwise noted)

Parameter	Symbol	Test Conditions	Value			Unit
			Min.	Typ.	Max.	
Drain-Source Breakdown Voltage	$V_{(BR)DSS}$	$V_{GS}=0V, I_D=250\mu A$	60	—	—	V
Zero Gate Voltage Drain Current	I_{DSS}	$V_{DS}=60V, V_{GS}=0V$	—	—	1	μA
Gate-Body Leakage Current	I_{GSS}	$V_{GS} = \pm 20V, V_{DS}=0V$	—	—	± 100	nA
Gate Threshold Voltage	$V_{GS(th)}$	$V_{DS} = V_{GS}, I_D = 250\mu A$	1.2	1.6	2.5	V
Static Drain-Source On-Resistance	$R_{DS(on)}$	$V_{GS} = 10V, I_D = 4.5 A$	—	27	32	m Ω
Forward Transconductance	g_{fs}	$V_{DS}=5V, I_D = 5A$	11	—	—	S
Diode Forward Voltage (Note3)	V_{SD}	$V_{GS}=0V, I_S=20A$	—	—	1.2	V
Continuous Source Current (Note2)	I_S		—	—	20	A
Reverse Recovery Time	t_{rr}	$T_J = 25^\circ C, I_F = 20A$ $di/dt = 100A/\mu s$ (Note3)	—	35	—	nS
Reverse Recovery Charge	Q_{rr}		—	53	—	nC
Input Capacitance	C_{iss}	$V_{GS}=0V, V_{DS}=30V,$ $f=1.0MHz$	—	1500	—	pF
Output Capacitance	C_{oss}		—	60	—	
Reverse Transfer Capacitance	C_{rss}		—	25	—	
Total Gate Charge	Q_g	$V_{GS}=10V, V_{DS}=30V,$ $I_D=4.5A$	—	47	—	nC
Gate-Source Charge	Q_{gs}		—	6	—	
Gate-Drain Charge	Q_{gd}		—	14	—	
Turn-on Delay Time	$t_{d(on)}$	$V_{DD}=30V, R_L=6.7\Omega$ $R_G=3\Omega, V_{GS}=10V$	—	5	—	ns
Turn-on Rise Time	t_r		—	2.6	—	
Turn-off Delay Time	$t_{d(off)}$		—	16.1	—	
Turn-off Fall Time	t_f		—	2.3	—	
Forward Turn-On Time	t_{on}	Intrinsic turn-on time is negligible (turn-on is dominated by LS+LD)				

Notes:

1. Repetitive Rating: Pulse width limited by maximum junction temperature.
2. Pulse Test: Pulse Width $\leq 300\mu \leq 10$ sec .
3. Surface Mounted on FR4 Board,s,t Duty Cycle $\leq 2\%$.
- 4.Guaranteed by design, not subject to production
5. EAS condition: $T_J=25, V_{DD}=30V, V_G=10V, L=0.5mH, R_g=25\Omega$



Test Circuit

1) EAS test Circuit

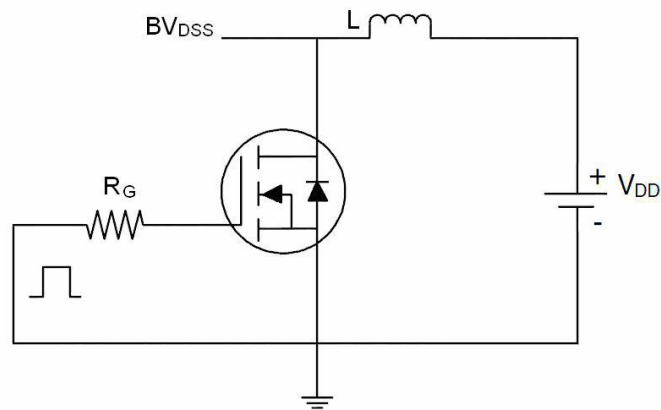

2) Gate charge test Circuit

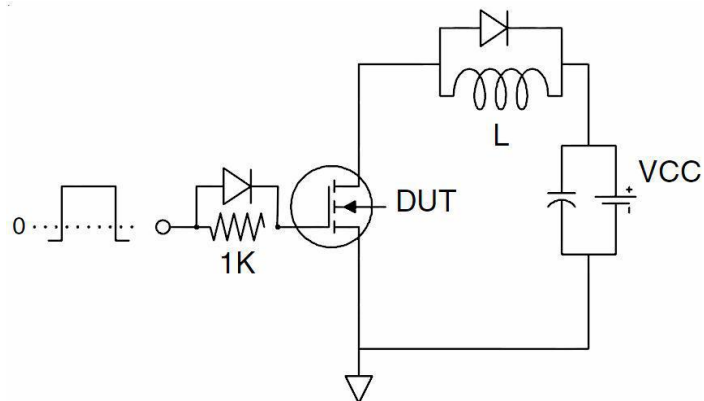

3) Switch Time Test Circuit

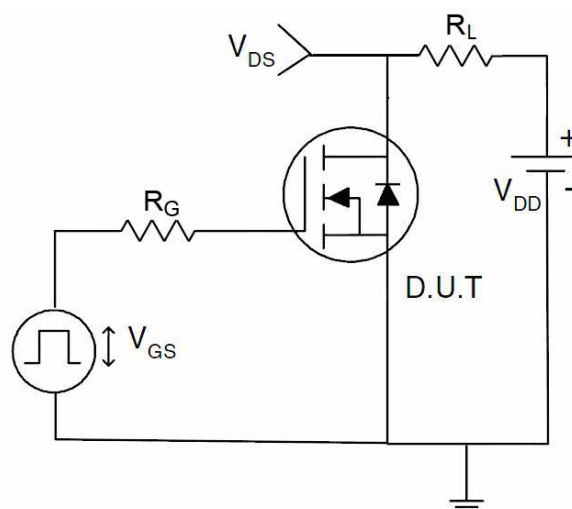



Typical Electrical and Thermal Characteristics (Curves)

Test Circuit

1) EAS test Circuit

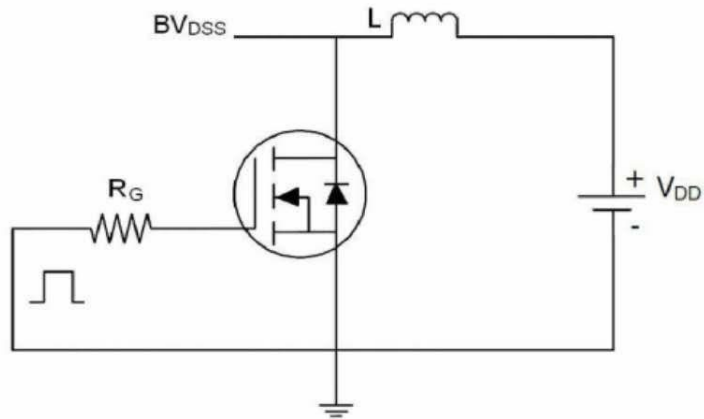

2) Gate charge test Circuit

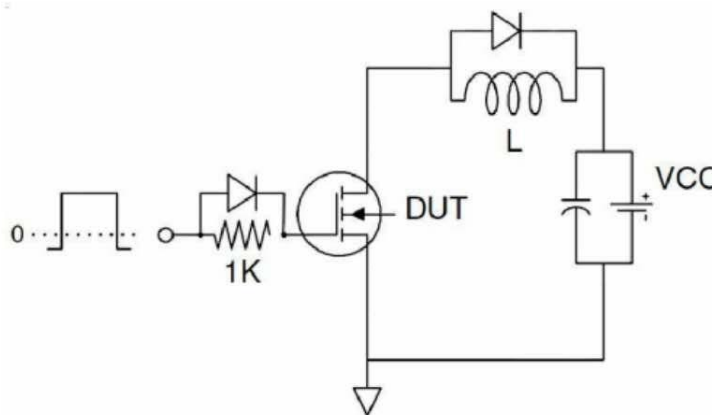

3) Switch Time Test Circuit

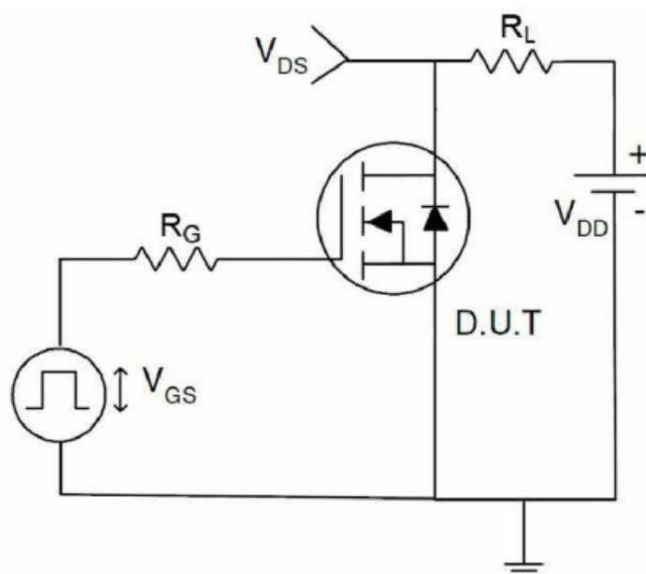



60V (V_{DS}) / 30A (I_D) N-Channel Enhancement-Mode MOSFET

Typical Electrical and Thermal Characteristics (Curves)

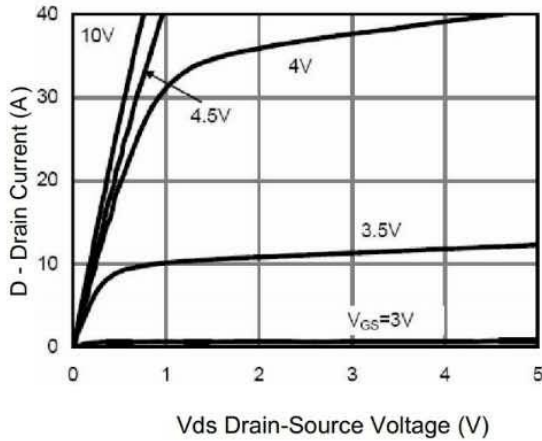

Figure 1 Output Characteristics

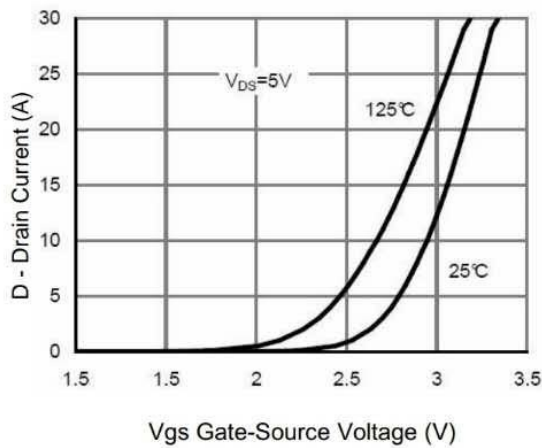

Figure 2 Transfer Characteristics

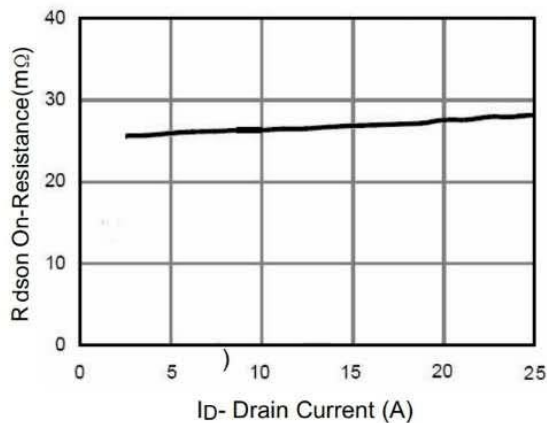

Figure 3 $R_{DS(on)}$ - Drain Current

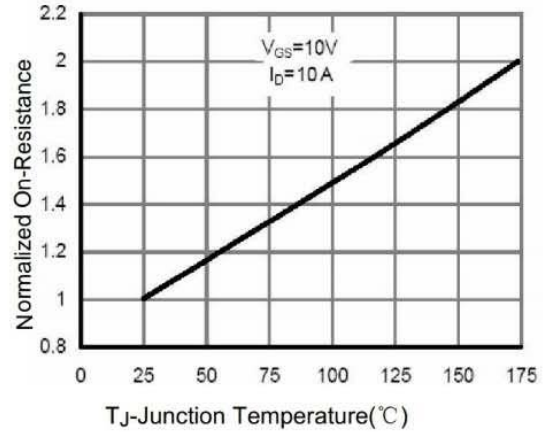

Figure 4 $R_{DS(on)}$ -Junction Temperature

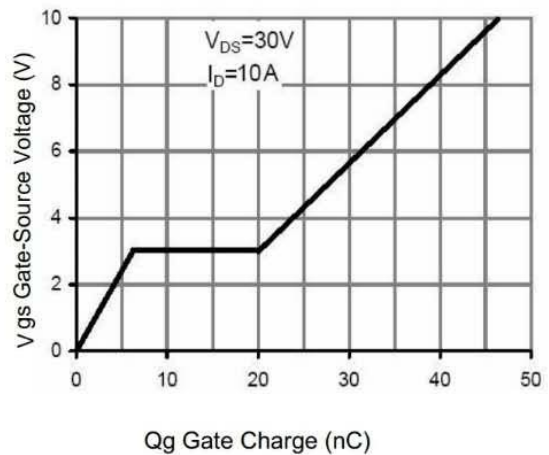

Figure 5 Gate Charge

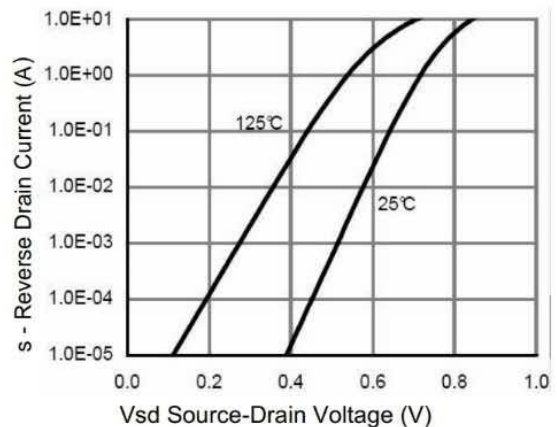

Figure 6 Source- Drain Diode Forward



60V (V_{DS}) / 30A (I_D) N-Channel Enhancement-Mode MOSFET

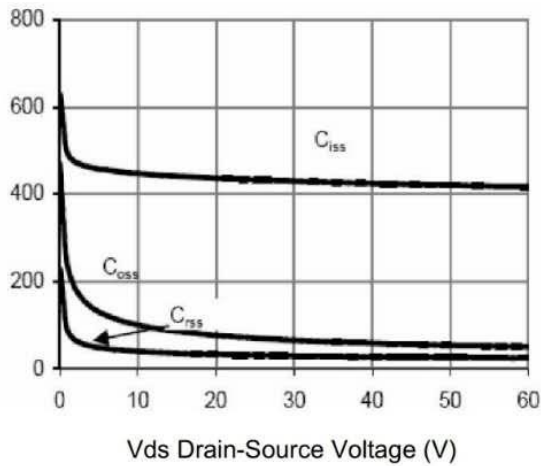

Figure 7 Capacitance vs V_{DS}

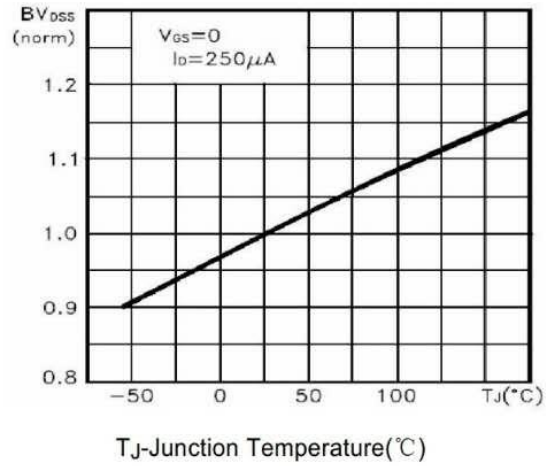

Figure 9 BV_{DS} vs Junction Temperature

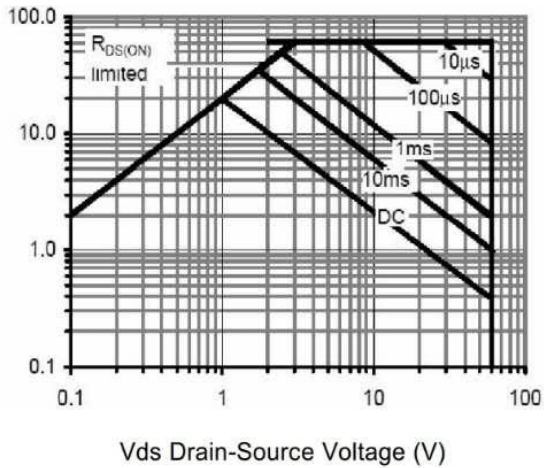

Figure 8 Safe Operation Area

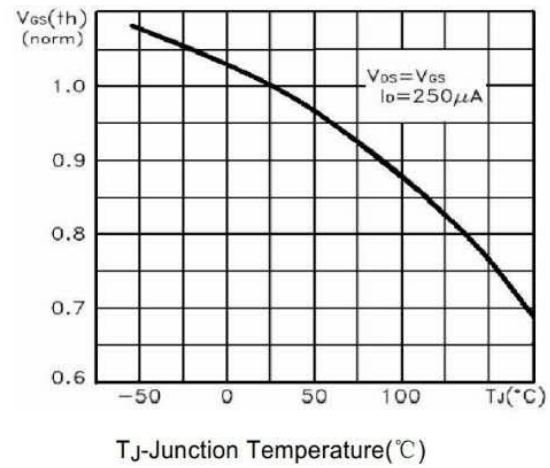

Figure 10 $V_{GS(th)}$ vs Junction Temperature

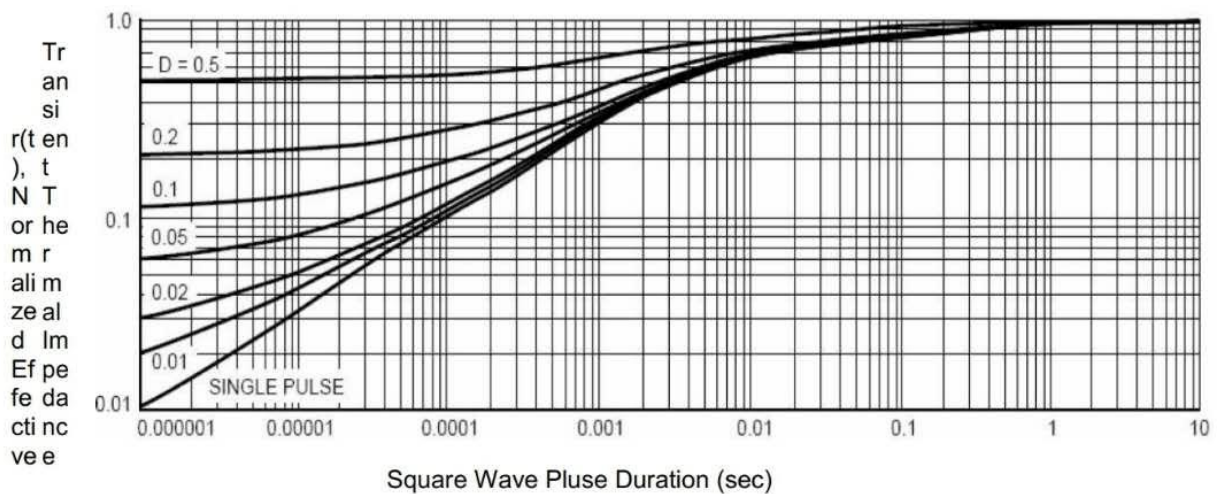
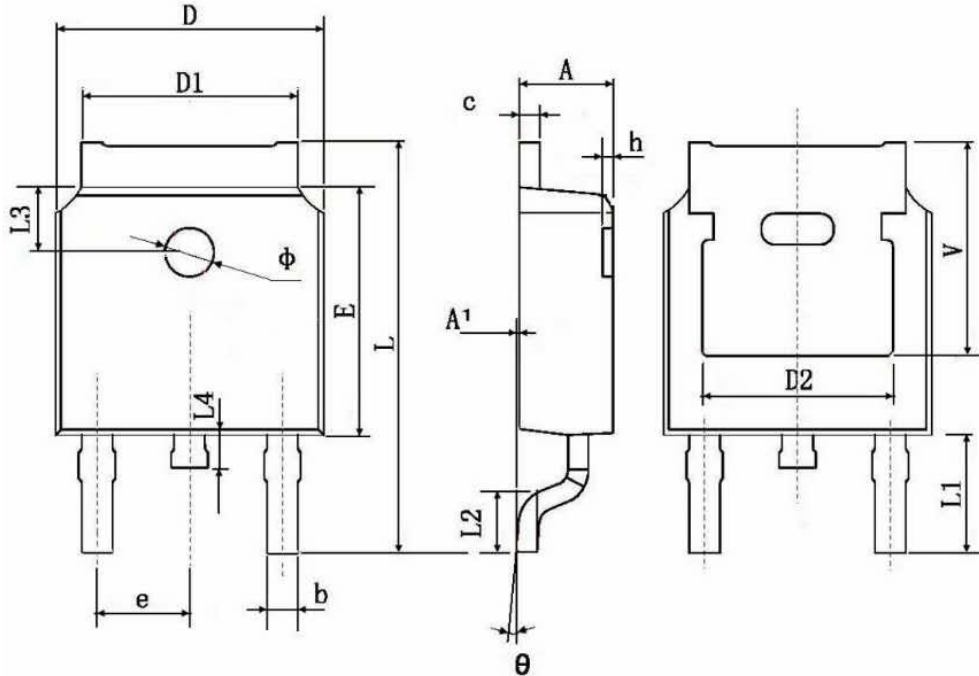

Figure 11 Normalized Maximum Transient Thermal Impedance



60V (V_{DS}) / 30A (I_D) N-Channel Enhancement-Mode MOSFET

TO-252 Package Information



Symbol	Dimensions In Millimeters		Dimensions In Inches	
	Min.	Max.	Min.	Max.
A	2.200	2.400	0.087	0.094
A1	0.000	0.127	0.000	0.005
b	0.660	0.860	0.026	0.034
c	0.460	0.580	0.018	0.023
D	6.500	6.700	0.256	0.264
D1	5.100	5.460	0.201	0.215
D2	0.483 TYP.		0.190 TYP.	
E	6.000	6.200	0.236	0.244
e	2.186	2.386	0.086	0.094
L	9.800	10.400	0.386	0.409
L1	2.900 TYP.		0.114 TYP.	
L2	1.400	1.700	0.055	0.067
L3	1.600 TYP.		0.063 TYP.	
L4	0.600	1.000	0.024	0.039
phi	1.100	1.300	0.043	0.051
theta	0°	8°	0°	8°
h	0.000	0.300	0.000	0.012
V	5.350 TYP.		0.211 TYP.	