

外壳 - HC-STA-B06-BWS-ELC-AL - 1411318

Please be informed that the data shown in this PDF Document is generated from our Online Catalog. Please find the complete data in the user's documentation. Our General Terms of Use for Downloads are valid (<http://download.phoenixcontact.com>)



HEAVYCON B6面板安装底座，带单锁扣，带平垫片，耐盐水铝材，可导电异形垫圈。

为什么选择该产品

- 在有电磁干扰的情况下可确保良好的屏蔽



关键商业数据

包装单位	1 STK
GTIN	 4 046356 927192
GTIN	4046356927192
海关税则号	8538900000
Sales Key	BF7APB

技术数据

尺寸

高度	30.5 mm
宽度	53 mm
长度	80.5 mm
开口长度	52 mm
开口宽度	35 mm

环境条件

外壳保护等级 (IP)	IP66
	IP67
外壳保护等级 (NEMA)	4 (UL 50e)
	4X (UL 50e)
	12 (UL 50e)
环境温度 (运行)	-40 °C ... 125 °C

外壳 - HC-STA-B06-BWS-ELC-AL - 1411318

技术数据

概述

注意事项	适用插芯HC-B6、BB10、DD24、M
尺寸	B6
外壳类型	面板安装底座
颜色	灰色铝
锁定类型	带单锁扣
扭矩	1.5 Nm ... 2 Nm (安装螺钉)
螺钉连接	无
外壳材料	压铸铝, 耐盐水
外壳表面材料	无镀层
密封材料	NBR, 导电
材料锁扣	PA

Environmental Product Compliance

China RoHS	环保使用期限：无限期 = EFUP-e
	无超标的有害物质

产品图

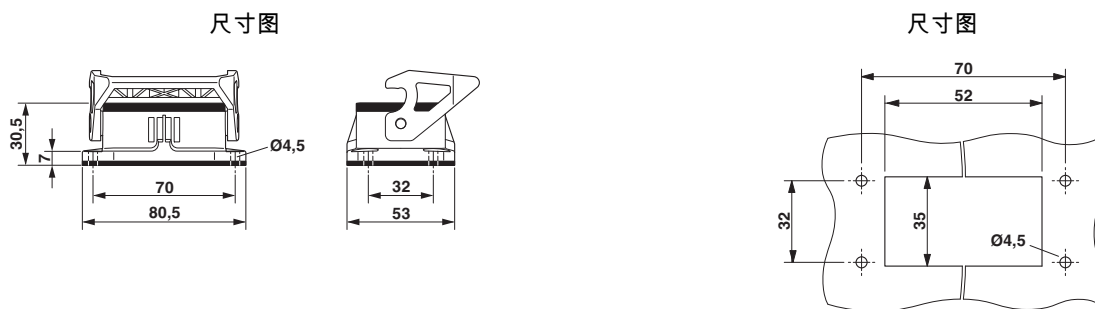

尺寸图

面板开口

认证

认证

认证

GL / UL认证 / cUL认证 / EAC / cULus认证

防爆认证

认证详情

外壳 - HC-STA-B06-BWS-ELC-AL - 1411318

认证

GL		http://exchange.dnv.com/tari/	6196614 HH
----	--	---	------------

UL认证		http://database.ul.com/cgi-bin/XYV/template/LISEXT/1FRAME/index.htm	E255026
------	--	---	---------

cUL认证		http://database.ul.com/cgi-bin/XYV/template/LISEXT/1FRAME/index.htm	E255026
-------	--	---	---------

EAC			RU C- DE.AI30.B.01102
-----	--	--	--------------------------

cULus认证		http://database.ul.com/cgi-bin/XYV/template/LISEXT/1FRAME/index.htm	
---------	--	---	--

附件

附件

外壳锁销

备用部件 - HC-STA-B06-SL-PLBK - 1412591



单锁扣，适合B6外壳，HC-EVO...AL和HC-STA...AL

密封

扁平密封 - HC-B06-SG-CBK - 1411483



备用扁平密封圈，用于HEAVYCON面板安装底座，HC-STA-...AL，B6型，可导电

外壳 - HC-STA-B06-BWS-ELC-AL - 1411318

附件

垫圈 - HC-B06-SP-CBK - 1411477



用于B6型HEAVYCON EVO基座支撑元件的异形垫圈，可导电

Phoenix Contact 2018 © - all rights reserved
<http://www.phoenixcontact.com>