



# PRODUCT SPECIFICATION

**MODEL: ZTM101BOEL3625**<◇>PRELIMINARY

SPECIFICATION

<◇>APPROVAL SPECIFICATION

CUSTOMER
APPROVED BY
DATE:

DESIGNED	CHECKED	APPROVED
张怡金	谢王豪	龙在忠

## REVISION STATUS

Version	Revise Date	Page	Content	Modified by
---------	-------------	------	---------	-------------



V1.0	2022.09.16	-	First Issued.	-

深圳市正通仁禾科技有限公司



TABLE OF CONTENTS

No.	CONTENTS	PAGE
	REVISION STATUS .....	1
	TABLE OF CONTENTS .....	3
1.	GENERAL DESCRIPTION .....	4
2.	MECHANICAL SPECIFICATION .....	4
3.	PIN DESCRIPTION .....	6
4.	ELECTRICAL CHARACTERISTICS .....	7
5.	INPUT SIGNAL TIMING .....	9
6.	OPTICAL CHARACTERISTICS .....	11
7.	RELIABILITY TEST ITEMS .....	14
8.	GENERAL PRECAUTION.....	16



## 1. GENERAL DESCRIPTION

### 1.1 DESCRIPTION

This LCM is a color active matrix thin film transistor (TFT) IPS liquid crystal display (LCD) that uses amorphous silicon TFT as a switching device. It is composed of a TFT LCD panel, Driver IC, FPC and Backlight, This TFT LCD has a 10.1-inch diagonally measured active display area with (1920 horizontal by 1080 vertical pixel) resolution.

### 1.2 FEATURES:

No.	Item	Specification	Unit
1	Panel Size	10.1"	inch
2	Number of Pixels	1920×RGB (3)×1080	pixels
3	Active Area	125.712(H)x223.488(V)	mm
4	Pixel Pitch	0.0376(W)×0.1128(V) x RGB	mm
5	Outline Dimension	229.91(W)×135.74(H)×2.8(D)	mm
6	Number of Colors	16.7M	-
7	Display Mode	Transmission mode, normally black	-
8	Viewing Direction	Full viewing	-
9	Display Format	RGB vertical stripe	-
10	Surface Treatment	HC,AG	-
11	Interface	LVDS	-
12	Backlight	White LED	-
13	Operation Temperature	0°C~+50°C	°C
14	Storage Temperature	-10°C~+60°C	°C
15	Aspect Ratio	-	-
16	Weight	TBD	g

## 2. MECHANICAL SPECIFICATION



A	B	C	D	E	F	G	H	I	V
第三角法		DATE 日期	PAGE 页数	1/1			版本	日期	修改原因
									内容描述

**RoHS**

**LCM图**

注意静电防护  
Attention to static electricity protection

## 展开图示

## 正面图示

## 反面图示

**展开图示**

**正面图示**

**反面图示**

正通料号: ZTM101BOEL3625

标签内容: 1013625 220809B0001

模组型号 缩减排+年月日+线别+流水号

背光LED电路: 9\*4=36 LED

入光方向 九点检测测试参考图

**正 式 图**

REV	版本	PART No.	ZTM101BOEL3625
DESIGNATION	物料号	101 3625 LCM	
MATERIAL	材质		
COLOR	颜色		
DATE	日期	2022-09-09	
SCALE	比例	1:1	
UNIT	单位	mm	

APPROVED BY: 核准  
CHECKED BY: 审核  
DRAWN BY: 绘图

深圳市正通仁禾科技有限公司  
Shen Zhen Ztrh Technology Co., Ltd.

**Notes:**

- Unit:mm.
- Do not scale drawing.
- All radii without dimension R0.2.
- Modification Mark.
- draft angle: 1°
- Backlight Luminance ::230cd/m<sup>2</sup>(Min), 280cd/m<sup>2</sup>(Typ)
- Luminance uniformity: 75% (min) (min/max\*100%)
- Unspecified Tolerance is ±0.2
- Operation conditions : If= 80mA, Vf=25. 8-28. 2V (MAX)
- Color coordinate:X=0. 288±0. 03, Y=0. 310±0. 03
- All materials comply with RoHS
- The measured value of Luminance and color coordinate bases FX's CA-310
- Check item:1~9



### 3. PIN DESCRIPTION

No.	Symbol	Function	Remark
1	VLED-	LED Cathode	
2	VLED-	LED Cathode	
3	VLED+	LED Anode	
4	VLED+	LED Anode	
5	GND	Ground	
6	OD0N	- LVDS differential data 0(ODD)	
7	OD0P	+ LVDS differential data 0(ODD)	
8	GND	Ground	
9	OD1N	- LVDS differential data 1(ODD)	
10	OD1P	+ LVDS differential data 1(ODD)	
11	GND	Ground	
12	OCLKN	- LVDS differential clock(ODD)	
13	OCLKP	+ LVDS differential clock(ODD)	
14	GND	Ground	
15	OD2N	- LVDS differential data 2(ODD)	
16	OD2P	+ LVDS differential data 2(ODD)	
17	GND	Ground	
18	OD3N	- LVDS differential data 3(ODD)	
19	OD3P	+ LVDS differential data 3(ODD)	
20	GND	Ground	
21	ED0N	- LVDS differential data 0(EVEN)	
22	ED0P	+ LVDS differential data 0(EVEN)	
23	GND	Ground	
24	ED1N	- LVDS differential data 1(EVEN)	
25	ED1P	+ LVDS differential data 1(EVEN)	
26	GND	Ground	
27	ECLKN	- LVDS differential clock(EVEN)	
28	ECLKP	+ LVDS differential clock(EVEN)	
29	GND	Ground	
30	ED2N	- LVDS differential data 2(EVEN)	
31	ED2P	+ LVDS differential data 2(EVEN)	
32	GND	Ground	
33	ED3N	- LVDS differential data 3(EVEN)	
34	ED3P	+ LVDS differential data 3(EVEN)	
35	STBYB	Stbyb Pin,Low active	
36	I2C_SDA	Serial address and data for I2C	
37	I2C_SCL	Clock signal for I2C interface	
38	RESET	Reset Pin,Low active	
39	VDDIN	Power supply VDDIN=3.3(TYP)	
40	VDDIN	Power supply VDDIN=3.3(TYP)	

## 4. ELECTRICAL CHARACTERISTICS

### 4.1 ELECTROMAGNETIC TOUCH BOARD

Parameter	Symbol	Condition	Spec			Unit
			Min	Typ	Max	
Differential input high Threshold Voltage	Vth	Vcm=1.2V	-	-	+0.1	V
Differential input low Threshold Voltage	Vtl	-	-0.1	-	-	V
Differential input common Mode Voltage	Vcm	-	1	1.2	$1.7 -  V_{id} /2$	V
LVDS input voltage	Vinlv	-	0.7	-	1.7	V
Different input voltage	Vid	-	0.1	-	0.6	V
Differerent input leakage Current	Ilvleak	-	-10	-	+10	uA

< Table7. LVDS mode DC electrical characteristics >

Single-ended:  
LVCLKP (R),  
LVCLKN (R),  
LVD[3:0]P (R),  
LVD[3:0]N (R)



Differential:  
LVCLKP (R) - LVCLKN (R),  
LVD[3:0]P (R) -  
LVD[3:0]N (R)

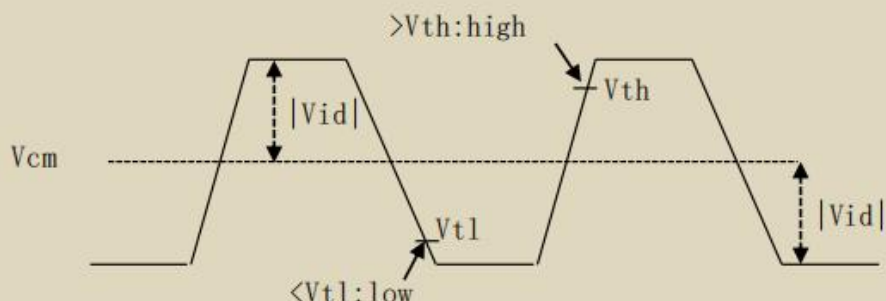

### 4.2 TFT LCD MODULE

< Table 4. LCD Module Electrical specifications > [Ta =25±2 °C]

Parameter	Symbol	Values			Unit	Notes
		Min.	Typ.	Max.		
Power Supply Voltage	VDDIN	3.0	3.3	3.6	V	
Power Supply Current	IDDIN	-	-	-	mA	Note 1
Power Consumption	PLCD	-	-	-	W	
Rush current	IRUSH	-	-	-	A	Note 2

Notes : 1. The supply voltage is measured and specified at the interface connector of LCM.  
 The current draw and power consumption specified is for VDD=3.3V, Frame rate  $f_v=60\text{Hz}$   
 Test Pattern of power supply current

a) Typ : Mosaic 5 x 5 Pattern(L0/L255)



b) Max : skip column (L0/L255)

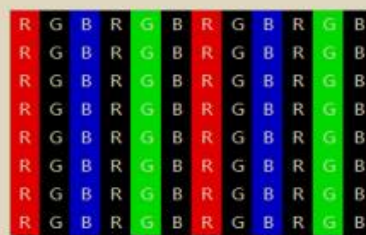

2. The duration of rush current is about 2ms and rising time of Power Input is 1ms(min)

### 4.3 BACKLIGHT UNIT

Item	Symbol	Values			Unit	Remark
		Min.	Typ.	Max.		
LED Current	Iled	-	80	-	mA	Total LED
Forward voltage	VF	-	27.9	-	V	IF=80mA
Reverse current	IR	-	-	50	$\mu\text{A}$	VR=5V, 1LED
Power dissipation	Pd	2232			mW	Total LED
Peak forward current	IFP	80			mA	1LED
Reverse Voltage	VR	5			V	1LED



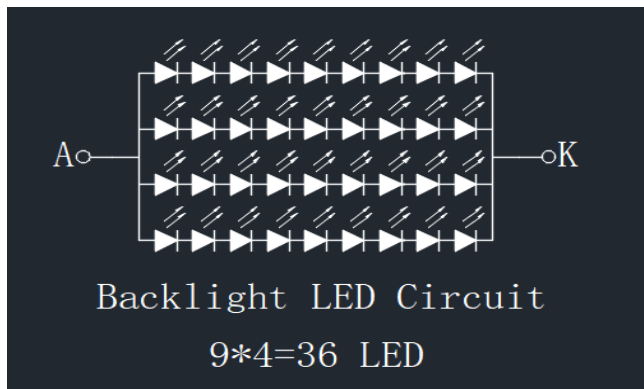

## 5. INPUT SIGNAL TIMING

### 5.1 Interface timing parameter

< Table8. SSC limitation of LVDS interface >

Parameter	Symbol	condition	Spec			Unit
			Min.	Typ.	Max	
Modulation frequency	SSCmf	LVDS clock frequency center at 80MHZ	-	-	200	KHZ
		LVDS clock frequency center at 60MHZ	-	-	150	KHZ
		LVDS clock frequency center at 40MHZ	-	-	100	KHZ
		LVDS clock frequency center at 20MHZ	-	-	50	KHZ
Modulation rate	SSCmr	LVDS clock frequency +SSCMR in the range of 20MHZ~80MHZ	-	-	±3	%



< Table9. Timing Parameter >

Item		Symbol	min	typ	max	UNIT	
LCD	Frame Rate	-	-	60	-	Hz	
Timing	DCLK	Frequency	fCLK	-	68.4	-	MHz
	Horizontal	Horizontal total time	tHP	-	1014	-	t <sub>CLK</sub>
		Horizontal Valid data	thd	960			t <sub>CLK</sub>
		Horizontal Pulse Width	tHsync	-	12	-	t <sub>CLK</sub>
		Horizontal Back Porch	tHBP	-	16	-	t <sub>CLK</sub>
		Horizontal Front Porch	tHFP	-	38	-	t <sub>CLK</sub>
	Vertical	Vertical total time	tvp	-	1124	-	t <sub>H</sub>
		Vertical Valid time	tvd	1080			t <sub>H</sub>
		Vertical Pulse Width	tVsync	-	5	-	t <sub>H</sub>
		Vertical Back Porch	tVBP	-	24	-	t <sub>H</sub>
Vertical Front Porch		tVFP	-	20	-	t <sub>H</sub>	

## 5.2 Power Sequence



To prevent a latch-up or DC operation of the LCD module, the power on/off sequence shall be as shown in below.

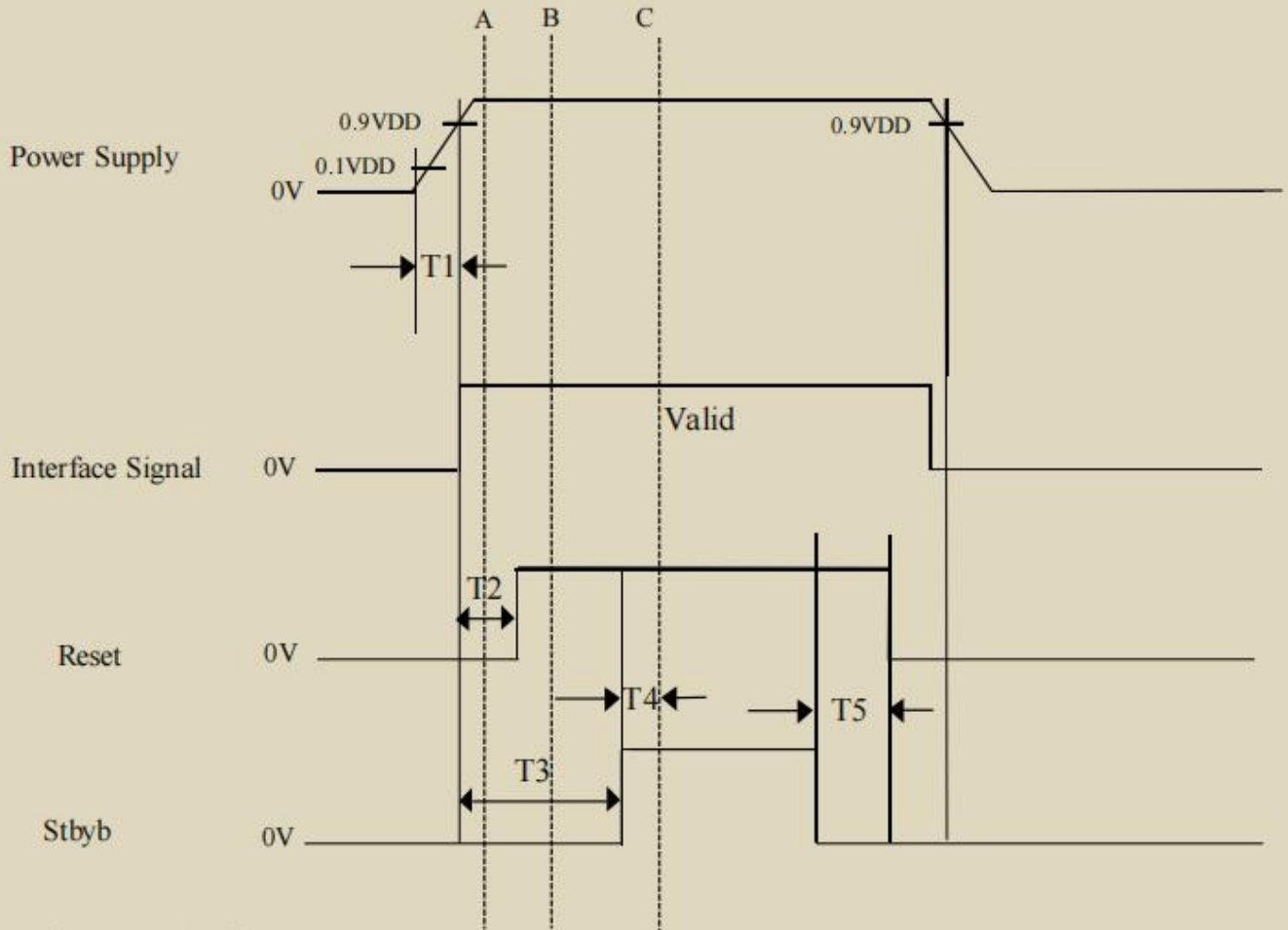

- $0.5\text{ ms} < T1 < 10\text{ ms}$
- $T2 > 10\text{ us}$
- $T3 > 16\text{ ms}$
- $T4 < 150\text{ ms}$
- $T5 > 90\text{ ms}$

Notes:

1. The valid LVDS signals(clock pair and all data pairs in toggling state) must be consistent with pane l resolution and suggestions.
2. The application system can apply LVDS signals from point A ( VCC1 is reday and not reset completeded ) ,B(reset completeded and in standby mode , or C(reset comoleted and non-standby mode)

## 6. OPTICAL CHARACTERISTICS

Item	Symbol	Min.	Typ.	Max.	Unit	Note
------	--------	------	------	------	------	------



Contrast Ratio		CR	800	1000	-		Note1 Note3
Luminance(center)		L	230	280	-	cd/m2	Note1 Note5 Note7
Luminous tolerance		LU	75	80		%	Note7
Response Time		Rising + Falling	-	25	35	ms	Note1 Note4
Viewing Angle K=Contrast Ratio>10	Horizontal	$\theta_{x^+}$	75	80	-	degree	Note2
		$\theta_{x^-}$	75	80	-		
	Vertical	$\theta_{y^+}$	75	80	-		
		$\theta_{y^-}$	75	80	-		
Color Chromaticity (CIE1931)	Red	x	Typ- 0.03	Typ+ 0.03	0.66	Note1 Note5 Note7	
		y			0.31		
	Green	x			0.25		
		y			0.65		
	Blue	x			0.14		
		y			0.07		
	White	x			0.30		
		y			0.30		
Color gamut (NTSC ratio)			85	-		%	

Note1: Definition of optical measurement system (BM-7)

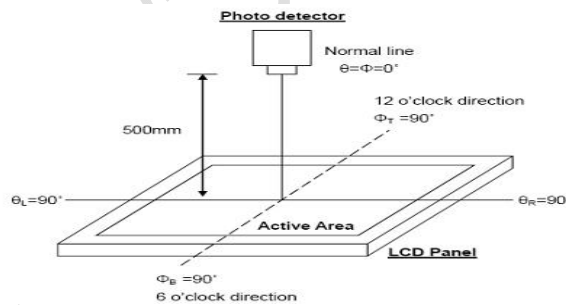

Note2: Definition of viewing angle range and measurement system

Viewing angle is measured at the center point of the LCD by CONOSCOPE (ergo-80).

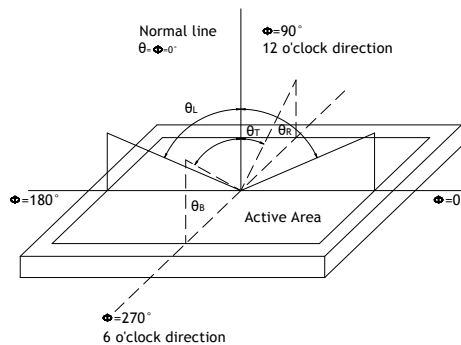

Note3: Definition of Response time

The response time is defined as the LCD optical switching time interval between

“White” state and “Black” state. Rise time (TON) is the time between photo detector output intensity changed from 90% to 10%. And fall time (TOFF) is the time between photo detector output intensity changed from 10% to 90%.

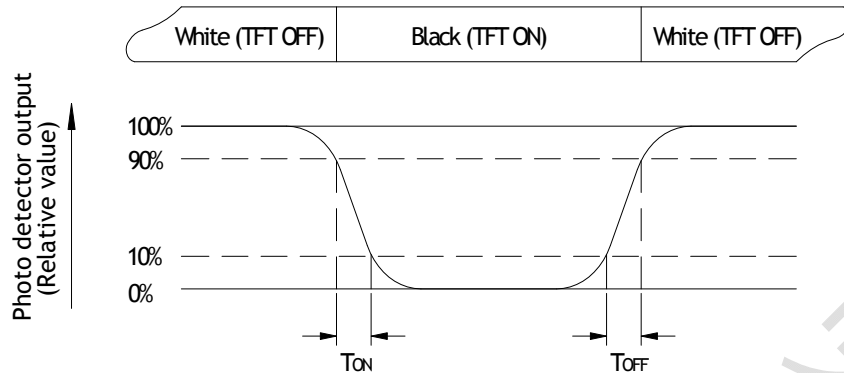

Fig. 6-3 Definition of response time

Note4: Definition of contrast ratio

$$\text{Contrast ratio(CR)} = \frac{\text{Luminance measured when LCD on the Whitestate}}{\text{Luminance measured when LCD on the Blackstate}}$$

“White state “: The state is that the LCD should drive by  $V_{white}$ .

“Black state”: The state is that the LCD should drive by  $V_{black}$ .

$V_{white}$ : To be determined  $V_{black}$ : To be determined.

Note5: Definition of color chromaticity (CIE1931)

Color coordinates measured at center point of LCD.

Note6: All input terminals LCD panel must be ground while measuring the center area of the panel. The LED driving condition is  $I_L=100\text{mA}$

Note7: Definition of Luminance Uniformity

Active area is divided into 9 measuring areas. Every measuring point is placed at the center of each measuring area.

$$\text{Luminance Uniformity (U)} = L_{\min} / L_{\max}$$

L----Active area length, W---- Active area width

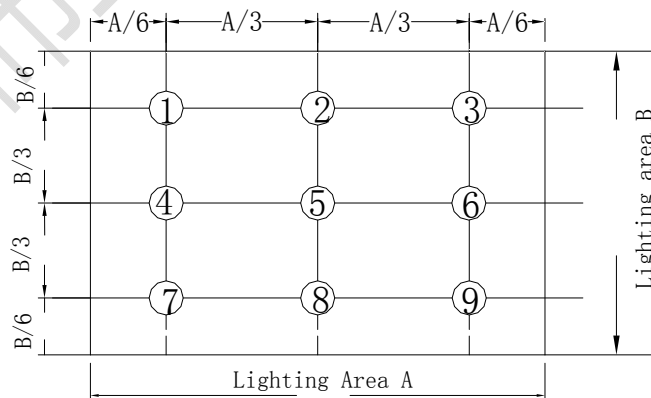

$B_{\max}$ : The measured maximum luminance of all measurement position.

$B_{\min}$ : The measured minimum luminance of all measurement position.

## 7. RELIABILITY TEST ITEMS



Test Item	Test Condition	Remark
High Temperature Storage	Ta=60°C; 240hrs	IEC60068-2-1 : 2007 GB2423.2-2008
Low Temperature Storage	Ta=-10°C;240hrs	IEC60068-2-1 : 2007 GB2423.1-2008
High Temperature Operation	Ta=50°C; 240Hrs	IEC60068-2-1 : 2007 GB2423.2-2008
Low Temperature Operation	Ta=-0°C; 240hrs	IEC60068-2-1 : 2007 GB2423.1-2008
High Temperature High Humidity Operation	Ta=50°C · 80%RH · 96Hrs(no condensation)	IEC60068-2-78 : 2001 GB/T2423.3-2006
Thermal Shock	-20°C(0.5h) ~ 70°C(0.5h) / 72 cycles	Start with cold temperature · End with high temperature · IEC60068-2-14:1984,GB2423.22-2002
Image Sticking	25°C ; 1hrs	-

Note1:Condition of image sticking test :25°C±2°C  
Operation with test pattern sustained for 1 hrs,then change to gray pattern immediately.after 5 mins,the mura must be disappeared completely

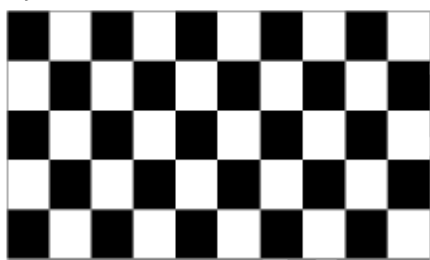

(a) Test Pattern (chess board Pattern )

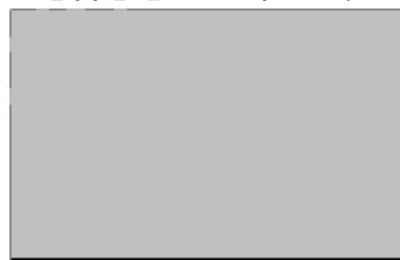

(b) Gray Pattern

### 7.2 VIBRATION&SHOCK

Test item	Conditions	Remark
Packing Shock (non-operation)	980m/s <sup>2</sup> ,6ms, ±x,y,z 3times for direction	IEC60068-2-27 : 1987 GB/T2423.5-1995
Packing Vibration (non-operation)	Frequency range:10 HZ~50HZ Stroke:1.0mm,sweep:10 HZ ~50HZ x,y,z 2 hours for each direction	IEC60068-2-32 : 1990 GB/T2423.8-1995

### 7.3 ESD

Test item	Conditions	Remark	
Electro Static Discharge Test (non-operation)	150pF · 330Ω · Contact:±4KV,Air:±8KV	1	Class C
	200pF · 0Ω · ±200V contact test	2	

Note: Measure point :

1. LCD glass and metal bezel
2. IF connector pins
3. ESD class B:some performance degradation allowed. Self-recoverable.  
No data lost,no hardware failures.



## 8. GENERAL PRECAUTION

### 8.1 SAFETY

1. Do not swallow any liquid crystal, even if there is no proof that liquid crystal is poisonous.
2. If the LCD panel breaks, be careful not to get liquid crystal to touch your skin.
3. If skin is exposed to liquid crystal, wash the area thoroughly with alcohol or soap.

### 8.2 STORAGE CONDITIONS

1. Store the panel or module in a dark place where the temperature is  $23\pm 5^{\circ}\text{C}$  and The humidity is below  $50\pm 20\%RH$ .

2. Store in anti-static electricity container.
3. Store in clean environment, free from dust, active gas, and solvent.
4. Do not place the module near organics solvents or corrosive gases.
5. Do not crush, shake, or jolt the module.

### 8.3 HANDLING PRECAUTIONS

1. Avoid static electricity which can damage the CMOS LSI.
2. The polarizing plate of the display is very fragile. So, please handle it very carefully.
3. Do not give external shock.
4. Do not apply excessive force on the surface.
5. Do not wipe the polarizing plate with a dry cloth, as it may easily scratch the Surface of plate.
6. Do not use ketonics solvent & Aromatic solvent, use with a soft cloth soaked with a cleaning naphtha solvent.
7. Do not operate it above the absolute maximum rating.
8. Do not remove the panel or frame from the module.
9. When the module is assembled, it should be attached to the system firmly, Be careful not to twist and bend the module.
10. Wipe off water droplets or oil immediately. If you leave the droplets for a long time, staining and discoloration may occur.
11. If the liquid crystal material leaks from the panel, it should be kept away from the eyes or mouth in case of contact with hands, legs or clothes, it must be washed away thoroughly with soap.

### 8.4 WARRANTY

1. The period is within twelve months since the date of shipping out under normal using and storage conditions.
2. Do not repaired or modified the LCM. It may cause function to lose efficacy, Starry does not warrant the LCM.
3. All process and material comply ROHS.