

General Description

The SN74HC/HCT365 is a hex buffer/line driver with 3-state outputs controlled by the output enable inputs (\overline{OEn}). A HIGH on \overline{OEn} causes the outputs to assume a high impedance OFF-state. Inputs include clamp diodes. This enables the use of current limiting resistors to interface inputs to voltages in excess of V_{CC} .

Features

- Input levels:
For SN74HC365: CMOS level
For SN74HCT365: TTL level
- 3-state outputs
- Specified from -40°C to $+125^{\circ}\text{C}$
- Packaging information: DIP16/SOP16/TSSOP16

Ordering Information

Product Model	Package Type	Marking	Packing	Packing Qty
XBLW SN74HC365N	DIP-16	74HC365N	Tube	1000Pcs/Box
XBLW SN74HC365DTR	SOP-16	74HC365	Tape	2500Pcs/Reel
XBLW SN74HC365TDTR	TSSOP-16	74HC365	Tape	3000Pcs/Reel
XBLW SN74HCT365N	DIP-16	74HCT365N	Tube	1000Pcs/Box
XBLW SN74HCT365DTR	SOP-16	74HCT365	Tape	2500Pcs/Reel
XBLW SN74HCT365TDTR	TSSOP-16	74HCT365	Tape	3000Pcs/Reel

Block Diagram And Pin Description

Block Diagram

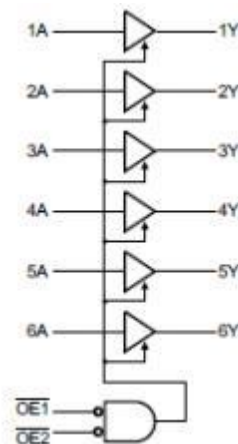

Figure 1. Logic symbol

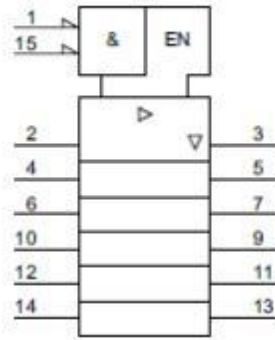

Figure 2. IEC logic symbol

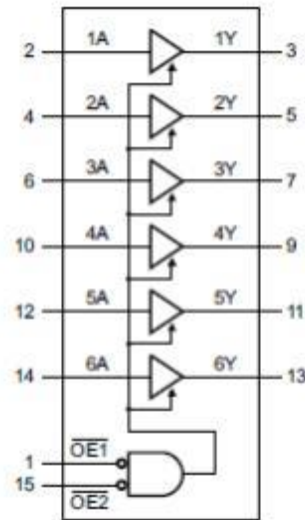

Figure 3. Functional diagram

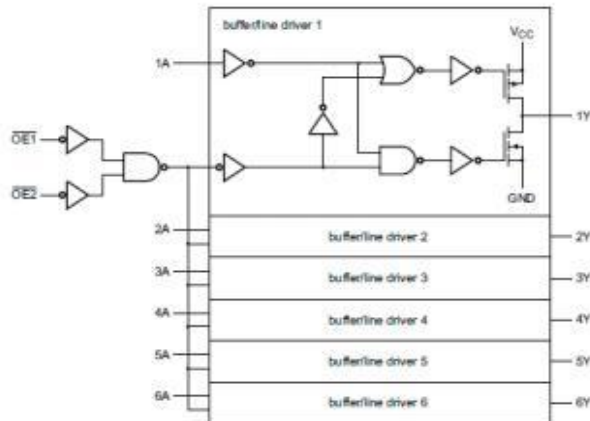
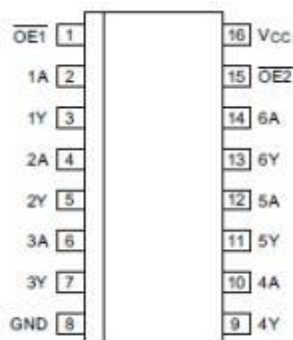

Figure 4. Logic diagram

Pin Configurations



Pin Description Function Table

Pin No.	Pin Name	Description
1	$\overline{OE}1$	output enable input 1 (active LOW)
2	1A	data input 1
3	1Y	data output 1
4	2A	data input 2
5	2Y	data output 2
6	3A	data input 3
7	3Y	data output 3
8	GND	ground (0V)
9	4Y	data output 4
10	4A	data input 4
11	5Y	data output 5
12	5A	data input 5
13	6Y	data output 6
14	6A	data input 6
15	$\overline{OE}2$	output enable input 2 (active LOW)
16	V _{CC}	supply voltage

Function Table

Input			Output
$\overline{OE}1$	$\overline{OE}2$	nA	nY
L	L	L	L
L	L	H	H
X	H	X	Z
H	X	X	Z

Note: H=HIGH voltage level; L=LOW voltage level; X=don'tcare; Z=high-impedance OFF-state.

Electrical Parameter

Absolute Maximum Ratings

(Voltages are referenced to GND (ground=0V), unless otherwise specified.)

Parameter	Symbol	Conditions	Min.	Max.	Unit
supply voltage	V _{CC}	-	-0.5	+7.0	V
input clamping current	I _{IK}	V _I < -0.5V or V _I > V _{CC} +0.5V	-	±20	mA
output clamping current	I _{OK}	V _O < -0.5V or V _O > V _{CC} +0.5V	-	±20	mA
output current	I _O	-0.5V < V _O < V _{CC} +0.5V	-	±35	mA
supply current	I _{CC}	-	-	70	mA
ground current	I _{GND}	-	-70	-	mA
storage temperature	T _{stg}	-	-65	+150	°C
total power dissipation	P _{tot}	-	-	500	mW
Soldering temperature	T _L	10s	DIP	245	°C
			SOP/TSSOP	260	

Recommended Operating Conditions

Parameter	Symbol	Conditions	Min.	Typ.	Max.	Unit
SN74HC365						
supply voltage	V_{CC}	-	2.0	5.0	6.0	V
input voltage	V_I	-	0	-	V_{CC}	V
output voltage	V_O	-	0	-	V_{CC}	V
input transition rise and fall rate	$\Delta t/\Delta V$	$V_{CC}=2.0V$	-	-	625	ns/V
		$V_{CC}=4.5V$	-	1.67	139	ns/V
		$V_{CC}=6.0V$	-	-	83	ns/V
ambient temperature	T_{amb}	-	-40	-	+125	°C
SN74HCT365						
supply voltage	V_{CC}	-	4.5	5.0	5.5	V
input voltage	V_I	-	0	-	V_{CC}	V
output voltage	V_O	-	0	-	V_{CC}	V
input transition rise and fall rate	$\Delta t/\Delta V$	$V_{CC}=4.5V$	-	1.67	139	ns/V
ambient temperature	T_{amb}	-	-40	-	+125	°C

DC Characteristics 1

 ($T_{amb}=25^{\circ}C$, voltages are referenced to GND (ground=0V), unless otherwise specified.)

Parameter	Symbol	Conditions	Min.	Typ.	Max.	Unit	
SN74HC365							
HIGH-level input voltage	V_{IH}	$V_{CC}=2.0V$	1.5	1.2	-	V	
		$V_{CC}=4.5V$	3.15	2.4	-	V	
		$V_{CC}=6.0V$	4.2	3.2	-	V	
LOW-level input voltage	V_{IL}	$V_{CC}=2.0V$	-	0.8	0.5	V	
		$V_{CC}=4.5V$	-	2.1	1.35	V	
		$V_{CC}=6.0V$	-	2.8	1.8	V	
HIGH-level output voltage	V_{OH}	$V_I = V_{IH} \text{ or } V_{IL}$	$I_O=-20\mu A; V_{CC}=2.0V$	1.9	2.0	-	V
			$I_O=-20\mu A; V_{CC}=4.5V$	4.4	4.5	-	V
			$I_O=-20\mu A; V_{CC}=6.0V$	5.9	6.0	-	V
			$I_O=-6.0mA; V_{CC}=4.5V$	3.98	4.32	-	V
			$I_O=-7.8mA; V_{CC}=6.0V$	5.48	5.81	-	V
LOW-level output voltage	V_{OL}	$V_I = V_{IH} \text{ or } V_{IL}$	$I_O=20\mu A; V_{CC}=2.0V$	-	0	0.1	V
			$I_O=20\mu A; V_{CC}=4.5V$	-	0	0.1	V
			$I_O=20\mu A; V_{CC}=6.0V$	-	0	0.1	V
			$I_O=6.0mA; V_{CC}=4.5V$	-	0.15	0.26	V
			$I_O=7.8mA; V_{CC}=6.0V$	-	0.16	0.26	V
input leakage current	I_I	$V_I=V_{CC} \text{ or } GND;$ $V_{CC}=6.0V$	-	-	± 1.0	μA	
OFF-state output current	I_{OZ}	$V_I=V_{IH} \text{ or } V_{IL}; V_{CC}=6.0V;$ $V_O=V_{CC} \text{ or } GND$	-	-	± 1.0	μA	
supply current	I_{CC}	$V_I=V_{CC} \text{ or } GND; I_O=0A; V_{CC}=6.0V$	-	-	8.0	μA	

input capacitance	C_i	-	-	3.5	-	pF	
SN74HCT365							
HIGH-level input voltage	V_{IH}	$V_{CC}=4.5V$ to $5.5V$		2.0	1.6	-	V
LOW-level input voltage	V_{IL}	$V_{CC}=4.5V$ to $5.5V$		-	1.2	0.8	V
HIGH-level output voltage	V_{OH}	$V_I = V_{IH}$ or V_{IL} ; $V_{CC}=4.5V$	$I_O=-20\mu A$	4.4	4.5	-	V
			$I_O=-6.0mA$	3.98	4.32	-	V
LOW-level output voltage	V_{OL}	$V_I = V_{IH}$ or V_{IL} ; $V_{CC}=4.5V$	$I_O=20\mu A$	-	0	0.1	V
			$I_O=6.0mA$	-	0.16	0.26	V
input leakage current	I_I	$V_I=V_{CC}$ or GND; $V_{CC}=5.5V$		-	-	± 1.0	μA
OFF-state output current	I_{OZ}	$V_I=V_{IH}$ or V_{IL} ; $V_{CC}=5.5V$; $V_O=V_{CC}$ or GND		-	-	± 1.0	μA
supply current	I_{CC}	$V_I=V_{CC}$ or GND; $I_O=0A$; $V_{CC}=5.5V$		-	-	8.0	μA
additional supply current	ΔI_{CC}	$V_I=V_{CC}-2.1V$; other inputs at V_{CC} or GND; $I_O=0A$	pins nA	-	-	360	μA
			pin $\overline{OE}1$	-	-	360	μA
			pin $\overline{OE}2$	-	-	324	μA
input capacitance	C_i	-	-	3.5	-	pF	

DC Characteristics 2

($T_{amb}=-40^{\circ}C$ to $+85^{\circ}C$, voltages are referenced to GND (ground=0V), unless otherwise specified.)

Parameter	Symbol	Conditions	Min.	Typ.	Max.	Unit	
SN74HC365							
HIGH-level input voltage	V_{IH}	$V_{CC}=2.0V$	1.5	-	-	V	
		$V_{CC}=4.5V$	3.15	-	-	V	
		$V_{CC}=6.0V$	4.2	-	-	V	
LOW-level input voltage	V_{IL}	$V_{CC}=2.0V$	-	-	0.5	V	
		$V_{CC}=4.5V$	-	-	1.35	V	
		$V_{CC}=6.0V$	-	-	1.8	V	
HIGH-level output voltage	V_{OH}	$V_I = V_{IH}$ or V_{IL}	$I_O=-20\mu A$; $V_{CC}=2.0V$	1.9	-	-	V
			$I_O=-20\mu A$; $V_{CC}=4.5V$	4.4	-	-	V
			$I_O=-20\mu A$; $V_{CC}=6.0V$	5.9	-	-	V
			$I_O=-6.0mA$; $V_{CC}=4.5V$	3.84	-	-	V
			$I_O=-7.8mA$; $V_{CC}=6.0V$	5.34	-	-	V
LOW-level output voltage	V_{OL}	$V_I = V_{IH}$ or V_{IL}	$I_O=20\mu A$; $V_{CC}=2.0V$	-	-	0.1	V
			$I_O=20\mu A$; $V_{CC}=4.5V$	-	-	0.1	V
			$I_O=20\mu A$; $V_{CC}=6.0V$	-	-	0.1	V
			$I_O=6.0mA$; $V_{CC}=4.5V$	-	-	0.33	V
			$I_O=7.8mA$; $V_{CC}=6.0V$	-	-	0.33	V
input leakage current	I_I	$V_I=V_{CC}$ or GND; $V_{CC}=6.0V$	-	-	± 1.0	μA	
OFF-state output current	I_{OZ}	$V_I=V_{IH}$ or V_{IL} ; $V_{CC}=6.0V$; $V_O=V_{CC}$ or GND	-	-	± 5.0	μA	
supply current	I_{CC}	$V_I=V_{CC}$ or GND; $I_O=0A$; $V_{CC}=6.0V$	-	-	80	μA	

SN74HCT365						
HIGH-level input voltage	V_{IH}	$V_{CC}=4.5V$ to $5.5V$		2.0	-	V
LOW-level input voltage	V_{IL}	$V_{CC}=4.5V$ to $5.5V$		-	0.8	V
HIGH-level output voltage	V_{OH}	$V_I = V_{IH}$ or V_{IL} ; $V_{CC}=4.5V$	$I_O=-20\mu A$	4.4	-	V
			$I_O=-6.0mA$	3.84	-	V
LOW-level output voltage	V_{OL}	$V_I = V_{IH}$ or V_{IL} ; $V_{CC}=4.5V$	$I_O=20\mu A$	-	0.1	V
			$I_O=6.0mA$	-	0.33	V
input leakage current	I_I	$V_I=V_{CC}$ or GND; $V_{CC}=5.5V$		-	± 1.0	μA
OFF-state output current	I_{OZ}	$V_I=V_{IH}$ or V_{IL} ; $V_{CC}=5.5V$; $V_O=V_{CC}$ or GND		-	± 5.0	μA
supply current	I_{CC}	$V_I=V_{CC}$ or GND; $I_O=0A$; $V_{CC}=5.5V$		-	80	μA
additional supply current	ΔI_{CC}	$V_I=V_{CC}-2.1V$; other inputs at V_{CC} or GND; $I_O=0A$	pins nA	-	450	μA
			pin $\overline{OE}1$	-	450	μA
			pin $\overline{OE}2$	-	405	μA

DC Characteristics 3

($T_{amb}=-40^{\circ}C$ to $+125^{\circ}C$, voltages are referenced to GND (ground=0V), unless otherwise specified.)

Parameter	Symbol	Conditions	Min.	Typ.	Max.	Unit	
SN74HC365							
HIGH-level input voltage	V_{IH}	$V_{CC}=2.0V$	1.5	-	-	V	
		$V_{CC}=4.5V$	3.15	-	-	V	
		$V_{CC}=6.0V$	4.2	-	-	V	
LOW-level input voltage	V_{IL}	$V_{CC}=2.0V$	-	-	0.5	V	
		$V_{CC}=4.5V$	-	-	1.35	V	
		$V_{CC}=6.0V$	-	-	1.8	V	
HIGH-level output voltage	V_{OH}	$V_I = V_{IH}$ or V_{IL}	$I_O=-20\mu A$; $V_{CC}=2.0V$	1.9	-	-	V
			$I_O=-20\mu A$; $V_{CC}=4.5V$	4.4	-	-	V
			$I_O=-20\mu A$; $V_{CC}=6.0V$	5.9	-	-	V
			$I_O=-6.0mA$; $V_{CC}=4.5V$	3.7	-	-	V
			$I_O=-7.8mA$; $V_{CC}=6.0V$	5.2	-	-	V
LOW-level output voltage	V_{OL}	$V_I = V_{IH}$ or V_{IL}	$I_O=20\mu A$; $V_{CC}=2.0V$	-	-	0.1	V
			$I_O=20\mu A$; $V_{CC}=4.5V$	-	-	0.1	V
			$I_O=20\mu A$; $V_{CC}=6.0V$	-	-	0.1	V
			$I_O=6.0mA$; $V_{CC}=4.5V$	-	-	0.4	V
			$I_O=7.8mA$; $V_{CC}=6.0V$	-	-	0.4	V
input leakage current	I_I	$V_I=V_{CC}$ or GND; $V_{CC}=6.0V$	-	-	± 1.0	μA	
OFF-state output current	I_{OZ}	$V_I=V_{IH}$ or V_{IL} ; $V_{CC}=6.0V$; $V_O=V_{CC}$ or GND	-	-	± 10	μA	
supply current	I_{CC}	$V_I=V_{CC}$ or GND; $I_O=0A$; $V_{CC}=6.0V$	-	-	160	μA	
SN74HCT365							
HIGH-level input voltage	V_{IH}	$V_{CC}=4.5V$ to $5.5V$	2.0	-	-	V	
LOW-level	V_{IL}	$V_{CC}=4.5V$ to $5.5V$	-	-	0.8	V	

input voltage							
HIGH-level output voltage	V_{OH}	$V_I = V_{IH} \text{ or } V_{IL}; V_{CC}=4.5V$	$I_O=-20\mu A$	4.4	-	-	V
			$I_O=-6.0mA$	3.7	-	-	V
LOW-level output voltage	V_{OL}	$V_I = V_{IH} \text{ or } V_{IL}; V_{CC}=4.5V$	$I_O=20\mu A$	-	-	0.1	V
			$I_O=6.0mA$	-	-	0.4	V
input leakage current	I_I	$V_I=V_{CC} \text{ or } GND; V_{CC}=5.5V$		-	-	± 1.0	μA
OFF-state output current	I_{OZ}	$V_I=V_{IH} \text{ or } V_{IL}; V_{CC}=5.5V; V_O=V_{CC} \text{ or } GND$		-	-	± 10	μA
supply current	I_{CC}	$V_I=V_{CC} \text{ or } GND; I_O=0A; V_{CC}=5.5V$		-	-	160	μA
additional supply current	ΔI_{CC}	$V_I=V_{CC}-2.1V; \text{ other inputs at } V_{CC} \text{ or } GND; I_O=0A$	pins nA	-	-	490	μA
			pin $\overline{OE}1$	-	-	490	μA
			pin $\overline{OE}2$	-	-	441	μA

AC Characteristics 1

($T_{amb}=25^\circ C$, $GND=0V$, $C_L=50pF$, unless otherwise specified.)

Parameter	Symbol	Conditions	Min.	Typ.	Max.	Unit	
SN74HC365							
nA tonY propagation delay	t_{pd}	see Figure 6	$V_{CC}=2.0V$	-	30	95	ns
			$V_{CC}=4.5V$	-	11	19	ns
			$V_{CC}=5.0V; C_L=15pF$	-	9	-	ns
			$V_{CC}=6.0V$	-	9	16	ns
$\overline{OE}n$ to nY enable time	t_{en}	see Figure 7	$V_{CC}=2.0V$	-	47	150	ns
			$V_{CC}=4.5V$	-	17	30	ns
			$V_{CC}=6.0V$	-	14	26	ns
$\overline{OE}n$ to nY disable time	t_{dis}	see Figure 7	$V_{CC}=2.0V$	-	61	150	ns
			$V_{CC}=4.5V$	-	22	30	ns
			$V_{CC}=6.0V$	-	18	26	ns
transition time	t_t	see Figure 6	$V_{CC}=2.0V$	-	14	60	ns
			$V_{CC}=4.5V$	-	5	12	ns
			$V_{CC}=6.0V$	-	4	10	ns
power dissipation capacitance	C_{PD}	per buffer; $V_I=GND$ to V_{CC}	-	40	-	pF	
SN74HCT365							
nA tonY propagation delay	t_{pd}	see Figure 6	$V_{CC}=4.5V$	-	14	25	ns
			$V_{CC}=5.0V; C_L=15pF$	-	11	-	ns
$\overline{OE}n$ to nY enable time	t_{en}	$V_{CC}=4.5V$; see Figure 7	-	18	35	ns	
$\overline{OE}n$ to nY disable time	t_{dis}	$V_{CC}=4.5V$; see Figure 7	-	23	35	ns	
transition time	t_t	$V_{CC}=4.5V$; see Figure 6	-	5	12	ns	
power dissipation capacitance	C_{PD}	per buffer; $V_I=GND$ to $V_{CC}-1.5V$	-	40	-	pF	

Note:

- [1] t_{pd} is the same as t_{PLH} and t_{PHL} .
 [2] t_{en} is the same as t_{PZL} and t_{PZH} .
 [3] t_{dis} is the same as t_{PLZ} and t_{PHZ} .
 [4] t_t is the same as t_{THL} and t_{TLH} .
 [5] C_{PD} is used to determine the dynamic power dissipation (P_D in uW).
 $P_D = C_{PD} \times V_{CC}^2 \times f_i \times N + \Sigma(C_L \times V_{CC}^2 \times f_o)$ where:
 f_i = input frequency in MHz;
 f_o = output frequency in MHz;
 C_L = output load capacitance in pF;
 V_{CC} = supply voltage in V;
 N = number of inputs switching;
 $\Sigma(C_L \times V_{CC}^2 \times f_o)$ = sum of outputs.

AC Characteristics 2

($T_{amb} = -40^\circ\text{C}$ to $+85^\circ\text{C}$, $GND = 0V$, $C_L = 50pF$, unless otherwise specified.)

Parameter	Symbol	Conditions	Min.	Typ.	Max.	Unit	
SN74HC365							
nA to nY propagation delay	t_{pd}	see Figure 6	$V_{CC} = 2.0V$	-	-	120	ns
			$V_{CC} = 4.5V$	-	-	24	ns
			$V_{CC} = 6.0V$	-	-	20	ns
$\bar{O}E_n$ to nY enable time	t_{en}	see Figure 7	$V_{CC} = 2.0V$	-	-	190	ns
			$V_{CC} = 4.5V$	-	-	38	ns
			$V_{CC} = 6.0V$	-	-	33	ns
$\bar{O}E_n$ to nY disable time	t_{dis}	see Figure 7	$V_{CC} = 2.0V$	-	-	190	ns
			$V_{CC} = 4.5V$	-	-	38	ns
			$V_{CC} = 6.0V$	-	-	33	ns
transition time	t_t	see Figure 6	$V_{CC} = 2.0V$	-	-	75	ns
			$V_{CC} = 4.5V$	-	-	15	ns
			$V_{CC} = 6.0V$	-	-	13	ns
SN74HCT365							
nA to nY propagation delay	t_{pd}	see Figure 6	$V_{CC} = 4.5V$	-	-	31	ns
$\bar{O}E_n$ to nY enable time	t_{en}	$V_{CC} = 4.5V$; see Figure 7		-	-	44	ns
$\bar{O}E_n$ to nY disable time	t_{dis}	$V_{CC} = 4.5V$; see Figure 7		-	-	44	ns
transition time	t_t	$V_{CC} = 4.5V$; see Figure 6		-	-	15	ns

Note:

- [1] t_{pd} is the same as t_{PLH} and t_{PHL} .
 [2] t_{en} is the same as t_{PZL} and t_{PZH} .
 [3] t_{dis} is the same as t_{PLZ} and t_{PHZ} .
 [4] t_t is the same as t_{THL} and t_{TLH} .

AC Characteristics 3

(T_{amb}=-40°C to +125°C, GND=0V, C_L=50pF, unless otherwise specified.)

Parameter	Symbol	Conditions	Min.	Typ.	Max.	Unit		
SN74HC365								
nA tonY propagation delay	t _{pd}	see Figure 6	V _{CC} =2.0V	-	-	145	ns	
			V _{CC} =4.5V	-	-	29	ns	
			V _{CC} =6.0V	-	-	25	ns	
$\overline{\text{OEn}}$ to nY enable time	t _{en}	see Figure 7	V _{CC} =2.0V	-	-	225	ns	
			V _{CC} =4.5V	-	-	45	ns	
			V _{CC} =6.0V	-	-	38	ns	
$\overline{\text{OEn}}$ to nY disable time	t _{dis}	see Figure 7	V _{CC} =2.0V	-	-	225	ns	
			V _{CC} =4.5V	-	-	45	ns	
			V _{CC} =6.0V	-	-	38	ns	
transition time	t _t	see Figure 6	V _{CC} =2.0V	-	-	90	ns	
			V _{CC} =4.5V	-	-	18	ns	
			V _{CC} =6.0V	-	-	15	ns	
SN74HCT365								
nA tonY propagation delay	t _{pd}	see Figure 6	V _{CC} =4.5V		-	-	38	ns
$\overline{\text{OEn}}$ to nY enable time	t _{en}	V _{CC} =4.5V; see Figure 7		-	-	53	ns	
$\overline{\text{OEn}}$ to nY disable time	t _{dis}	V _{CC} =4.5V; see Figure 7		-	-	53	ns	
transition time	t _t	V _{CC} =4.5V; see Figure 6		-	-	18	ns	

Note:

- [1] t_{pd} is the same as t_{PLH} and t_{PHL}.
- [2] t_{en} is the same as t_{PZL} and t_{PZH}.
- [3] t_{dis} is the same as t_{PLZ} and t_{PHZ}.
- [4] t_t is the same as t_{THL} and t_{TLH}.

Testing Circuit

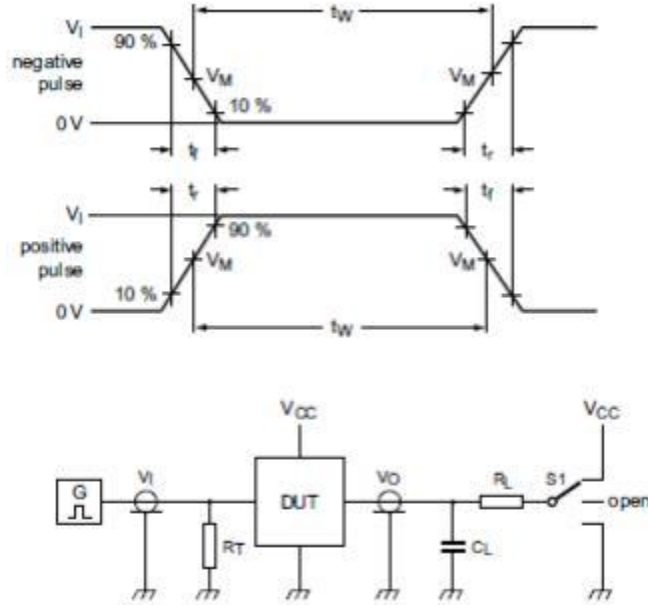

Figure 5. Test circuit for measuring switching times

Definitions for test circuit:

R_L =Load resistance.

C_L =Load capacitance including jig and probe capacitance.

R_T =Termination resistance should be equal to the output impedance Z_o of the pulse generator. S1=Test selection switch.

AC Testing Waveforms

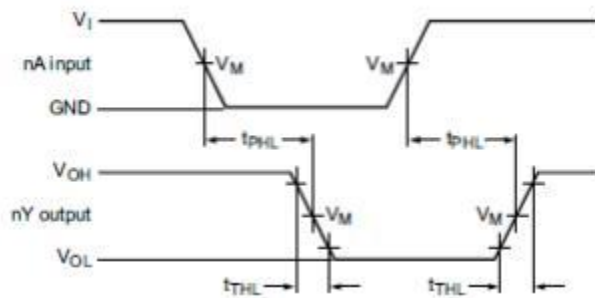

Figure 6. Input (nA) to output (nY) propagation delays and output transition times

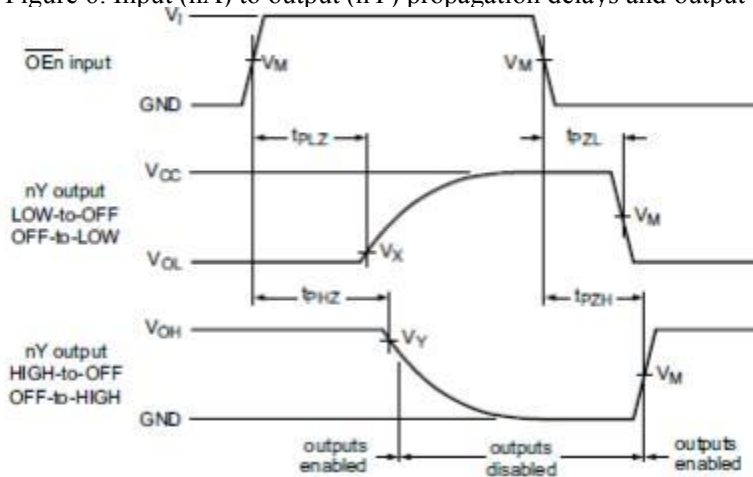

Figure 7. 3-state enable and disable times

Measurement Points

Type	Input	Output		
	V_M	V_M	V_X	V_Y
SN74HC365	$0.5 \times V_{CC}$	$0.5 \times V_{CC}$	$0.1 \times V_{CC}$	$0.9 \times V_{CC}$
SN74HCT365	1.3V	1.3V	$0.1 \times V_{CC}$	$0.9 \times V_{CC}$

Test Data

Type	Input		Load		S1 position		
	V_i	t_r, t_f	C_L	R_L	$t_{PHL},$ t_{PLH}	$t_{PZH},$ t_{PHZ}	$t_{PZL},$ t_{PLZ}
SN74HC365	V_{CC}	6ns	15pF, 50pF	1k Ω	open	GND	V_{CC}
SN74HCT365	3V	6ns	15pF, 50pF	1k Ω	open	GND	V_{CC}

Package Information

DIP16

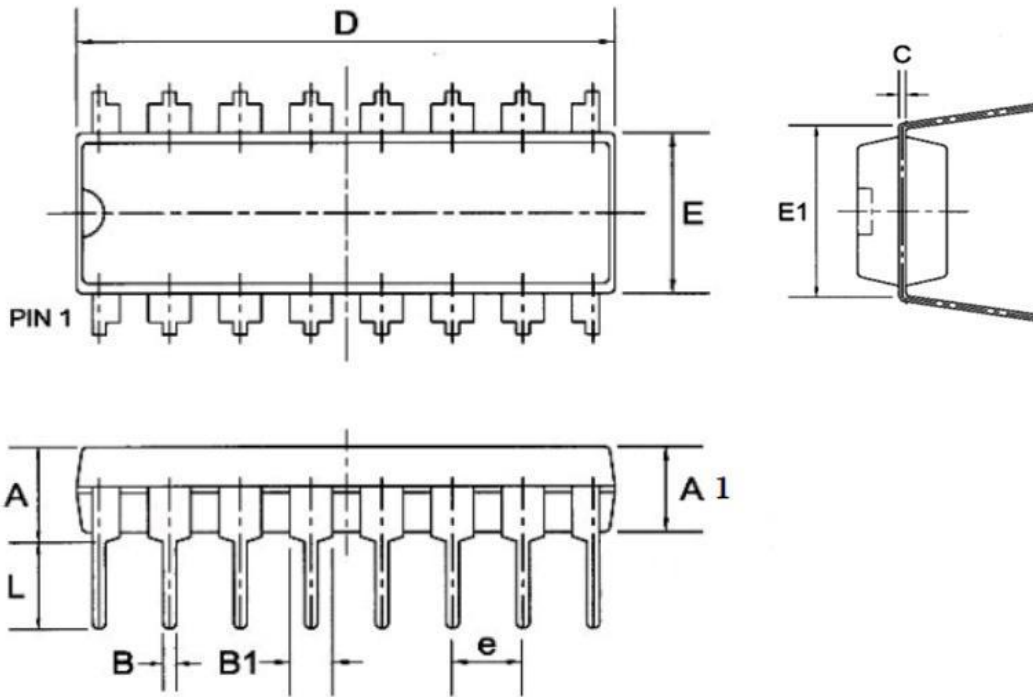

Symbol	Dimensions in Millimeters		
	Min	Nom	Max
A	--	--	4.31
A1	3.15	3.30	3.65
B	--	0.50	--
B1	--	1.6	--
C	--	0.27	--
D	19.00	19.20	19.60
E	6.20	6.50	6.60
E1	--	8.0	--
e	--	2.3	--
L	3.00	3.20	3.60

SOP16

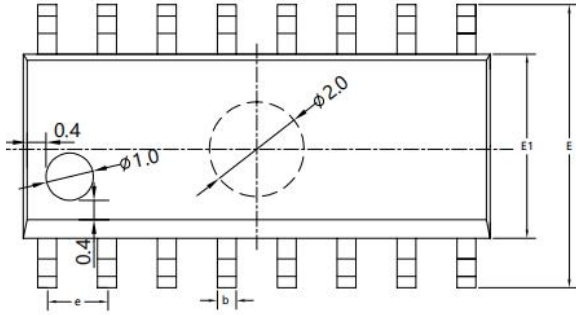
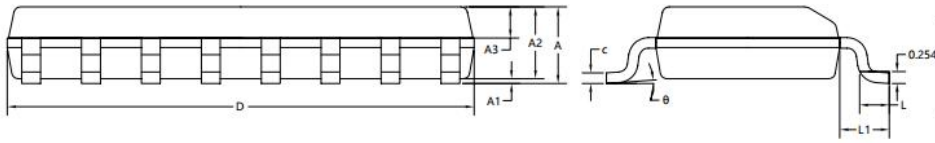

SYMBOL	MILLIMETER		
	MIN	NOM	MAX
A	1.50	1.60	1.70
A1	0.10	0.15	0.25
A2	1.40	1.45	1.50
A3	0.60	0.65	0.70
b	0.30	0.40	0.50
c	0.15	0.20	0.25
D	9.80	9.90	10.00
E	5.80	6.00	6.20
E1	3.85	3.90	3.95
e	1.27BSC		
L	0.50	0.60	0.70
L1	1.05BSC		
θ	0°	4°	8°

TSSOP16

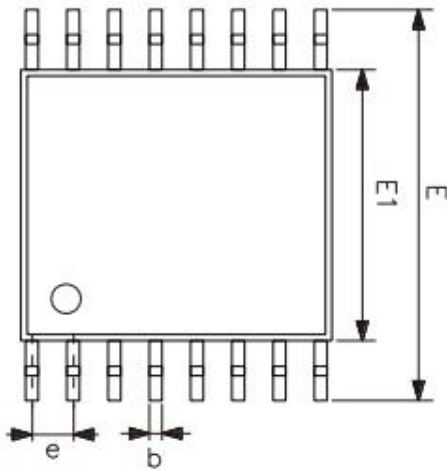
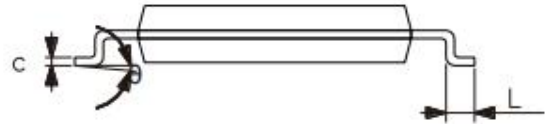
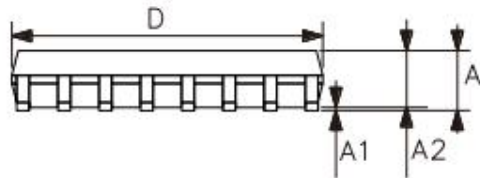

Symbol	Dimensions (mm)	
	Min.	Max.
A	-	1.20
A1	0.05	0.15
A2	0.80	1.05
b	0.19	0.30
c	0.09	0.20
D	4.90	5.10
E1	4.30	4.50
E	6.20	6.60
e	0.65	
L	0.45	0.75
θ	0°	8°

Statement:

- ◇ Shenzhen xinbole electronics co., ltd. reserves the right to change the product specifications, without notice!
Before placing an order, the customer needs to confirm whether the information obtained is the latest version, and verify the integrity of the relevant information.
- ◇ Any semiconductor product is liable to fail or malfunction under certain conditions, and the buyer shall be responsible for complying with safety standards in the system design and whole machine manufacturing using Shenzhen xinbole electronics co., ltd products, and take appropriate security measures to avoid the potential risk of failure may result in personal injury or property losses of the situation occurred!
- ◇ This document is for reference only, and the actual use should be based on the application test results.
- ◇ Product performance is never ending, Shenzhen xinbole electronics co., ltd will be dedicated to provide customers with better performance, better quality of integrated circuit products.