

REV. A	ECN NO. Initial Release	DATE 2015/11/10	SIGN Fisher	DESCRIPTION Change To Rev.A

THIS DOCUMENT IS SUBJECT TO CHANGE WITHOUT NOTICE. IT IS CONFIDENTIAL AND A PROPERTY OF Amphenol LTW. DISCLOSURE TO THIRD PARTY HAS TO BE AUTHORIZED BY Amphenol LTW.

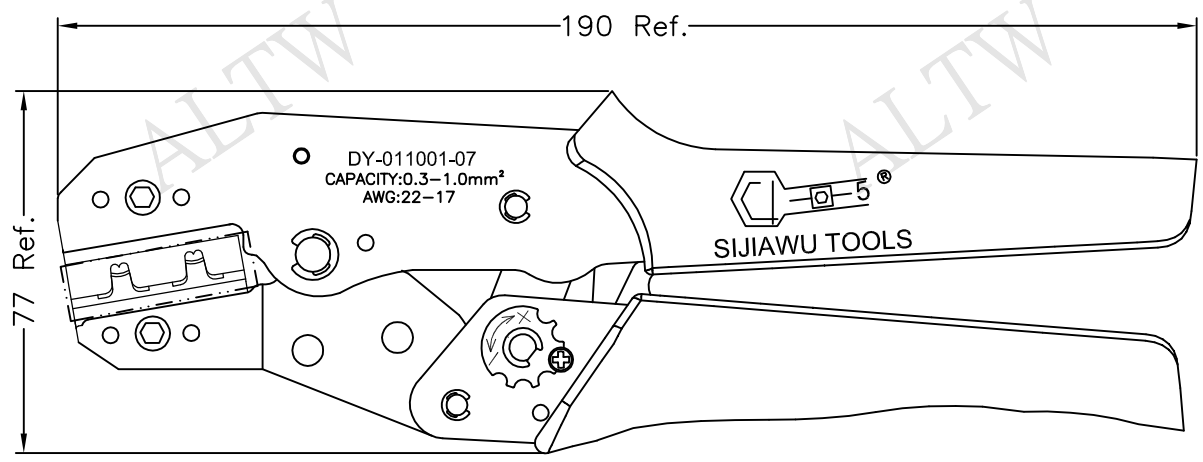

Front View

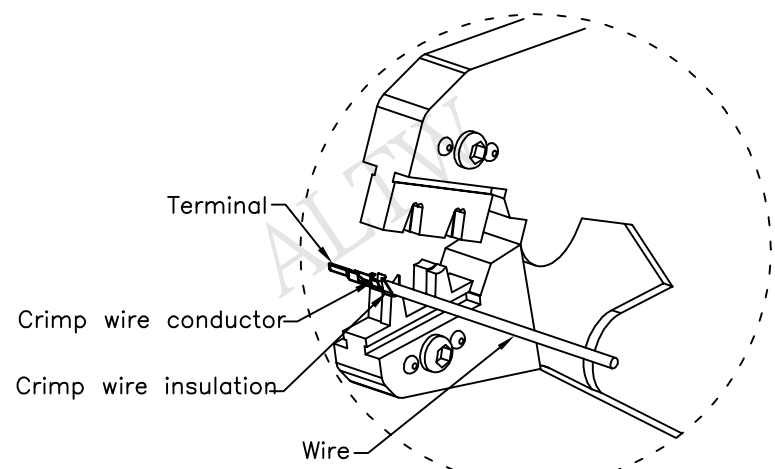
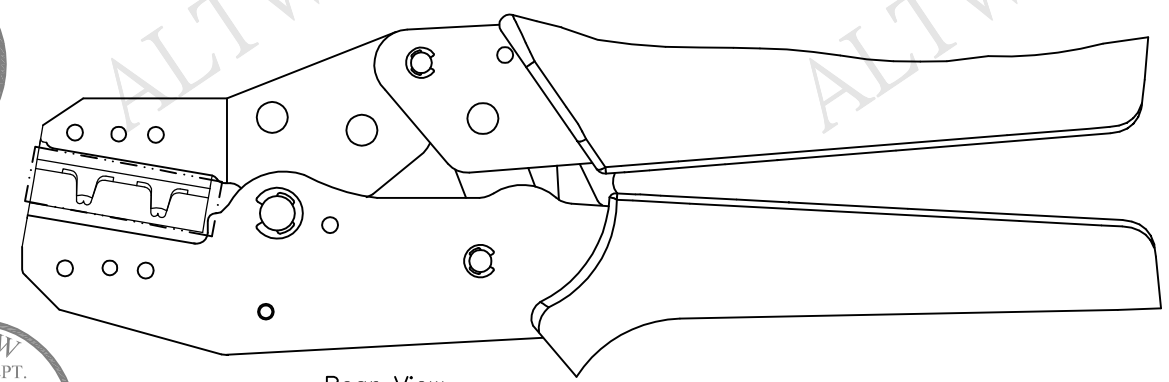

Rear View

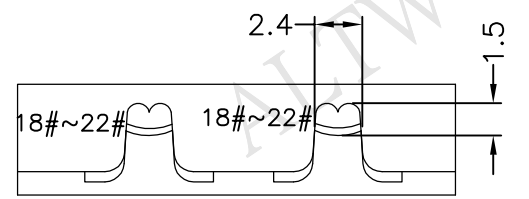

Front View

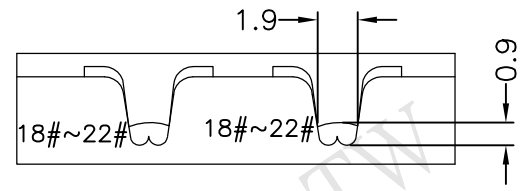

Rear View

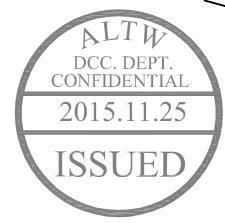

Note:

- \* @@Important Dimension.
- \* Supper: 菲克蘇, DY-011001-07
- \* Tool Material: 特殊鋼, Black; Jack color is blue
- \* Applicable wire range: 18~22AWG(0.32~0.85mm<sup>2</sup>)
- \* Tool weight: 0.35Kg

UNIT:mm	TITLE SSL1.2 CRIMPING TOOL	
TOLERANCE	SCALE Free	SHEET 1 OF 1
REV. A	SIZE A4	QC :Inspection Item

**Amphenol LTW**  
安費諾亮泰企業股份有限公司

ITEM NO CTL-204501	DRAWN BY Fisher	DATE 2014/11/10
DWG NO CTL-204501	CHECKED BY Victor	DATE 2014/11/10
CUSTOMER ALTW	APPROVED BY Kevin	DATE 2014/11/10